

LTU9000-DC

Conveyor Fed Bottle Leak Detector

User Guide

PLASTECH
CONTROL SYSTEMS



www.plastech-controls.com

Covers Model Numbers

LTU9000-DC-1
LTU9000-DC-2
LTU9000-DC-3
LTU9000-DC-4
LTU9000-DC-5
LTU9000-DC-6
LTU9000-DC-8
LTU9000-DC-10
LTU9000-DC-12

SAFETY WARNING

Electrical machinery contains hazardous voltages. Installation, servicing and adjustment is only to be performed by qualified personnel.

Do not tamper with this device.

Contents

1 Overview	5
•Features •Options	
2 Specification	11
•Performance Table	
1 General Machine Operation	13
2 Quick Set Guide	14
3 Displays and Settings	16
•Displays •Leak Test Settings •I/O Screen	
4 Principle of Operation	22
5 Installation	23
•Initial Specification of Equipment •Conveyor •Location •Installation Layout •Mounting •Supplies •Piping •Photoswitches •Testing	
6 Battery	30
7 Component Numbering Scheme	31
8 Function Number Cross-Reference	32
9 Input / Output Listing	33
•Notes	
10 Schematics	35

11 Maintenance 50

•Periodic Maintenance

12 Leak Detector Parts List 51

13 Fallen Bottle Ejection 54

•Fallen Bottle Sensing Installation and Setting Up •Handle Flash Detection

1 Overview

The LTU9000-DC leak detector is an in-line, bottle leak detection system capable of testing from 1 to 24 bottles at a time, with throughput to 240 bottles per minute depending on the configuration (see table 2.1 on page 12).

The LTU9000-DC is designed for 100% leak testing of blow moulding machine output. Several options are now available to allow this system to perform a variety of important additional bottle operations.

1.1 Features

The LTU9000-DC series of leak testers have many advanced features:

- High accuracy leakage measurement

The system uses a sensitive pressure transducer with a low noise amplifier and high speed, high-resolution analog to digital converter. This minimizes measurement errors.

- Flexible bottle transport system

Timings can be easily adjusted to optimize bottle transport, where required, without sacrificing test time.

1.1.1 Colour TFT Touch-Screen Microprocessor control system

It is now cost effective to use a modern touch-screen operator interface, rather than a simple digital readout. This has many advantages:

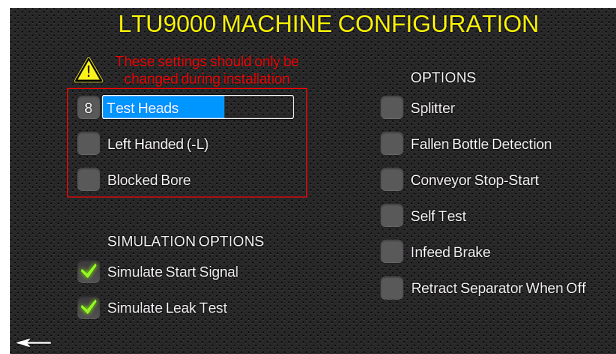

- Extremely flexible design. Extra features and customizations can be easily integrated into existing systems.
- All test results, displays and counts are displayed together on the main displays page. This enables evaluation of the status of the system at a glance.
- All settings are displayed together on a settings page, allowing easy inspection and modification.
- All input and output states are displayed together on a diagnostics page. This allows quick faultfinding.
- The graphics based nature of the screen allows descriptive text and graphics to appear identifying all settings, results and warnings.
- Setting changes can be locked out if required.
- International - Since all information is presented on the touch screen display, it is easy to change the program to use another language (where the system is to be used in a non - English speaking country).

1.1.2 High Reliability

This is possible due to technology improvement, reduced component count, integration of all electrical functions onto the PCB, and an in-depth understanding of failure mechanisms.

1.1.3 Modular pneumatic system

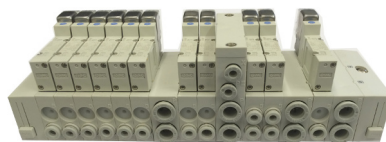

Easily Customized Modular Pneumatics System

- Allows quick customization for special needs.
- Allows easy expansion of system to include extra facilities even after installation.

1.1.4 Cost Effective

The circuit cards have been designed and programmed specifically for this application. Great care has been taken to ensure that the system is easily re-programmable, expandable and reliable. This means that the performance and cost limitations of using a bought-in Programmable Logic Controller are avoided.

1.1.5 Wide Range of Options

The leak tester design is highly flexible with respect to software, electronics, pneumatics and mechanics. This allows a wide range of options (see following page) to be added at any time, even after installation.

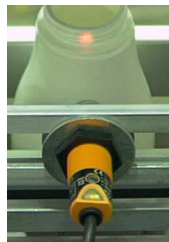

Auto-tuned Photoswitch with Visible Spot

1.2 Options

1.2.1 Extra Test Channels

It is straightforward to add additional test channels at any time, in order to increase throughput. This allows the leak tester to keep up with ever-increasing

blow molding machine speeds, without over-specifying the system at purchase time.

1.2.2 Choked Bore / Ovality Test

A probe fitted to the test head checks whether the neck is occluded or deformed.

1.2.3 Height Check

A fiber-optic sensor checks that the bottle is not too tall. This can detect folded over base flash on some bottles, as well as neck flash.

1.2.4 Auxiliary Sensors

Spare inputs are available which can be used to connect other sensors, which examine the bottle during the leak test. Examples might be label sensors, flash detection sensors or vision systems. The leak tester would fail the bottle if any of these inputs were triggered.

1.2.5 Bottle transport options

A variety of bottle transport options can be fitted to replace the standard method. It is recognised that the standard method may not always be suitable, although we have found that is the most flexible as well as the most cost effective. Options include side clamps and holding moulds.

1.2.6 Stabilization Plate / Brush

A pneumatically operated mechanism can be fitted to the infeed of the leak tester. This is only required when the conveyor is to be fed directly from the output of a blow molding machine with violent take-out movements. The plate supports the queue of bottles when push-out occurs. The plate then opens, allowing the bottles to travel down the conveyor.

1.2.7 Batch Counter / Diverter

This is a simple system intended to assist the scramble packing of bottles. A diverter mechanism at the end of the conveyor allows bottles to go into one or the other of two boxes. A preset count is entered into the system. Each time the count is reached, the diverter changes state. The bottles fall into the new box while the previous box, now full, is taken away and replaced. An optional alarm and reset button is available to alert an operator.

1.2.8 Multi-Gate Scramble Packing System

Bottles are diverted off the main conveyor into packing cartons, at a number of stations.

Having more than one packing station allows a single operator to look after several lines of production, since attention is only required periodically. A box can be changed at any time, within the time taken to fill the next two boxes.

Because the system is integrated with the leak detector, there are no problems with unexpected queuing causing a jam at the leak tester.

The number of bottles per box can be easily set to any value required.

1.2.9 Vacuum Operation

The system usually pressurizes the bottles during the leak test. However, it is possible to supply the system for vacuum operation where required.

1.2.10 Special test pressure

The system test pressure is adjustable over a limited range (see specification). If this range is not sufficient, a different transducer can be fitted to allow any test pressure desired.

1.2.11 Data logging / SPC

The standard system maintains counts of passed and failed bottles. More extensive data logging and SPC features can be implemented by exchanging the controller PCB for one with the SPC option fitted.



LTU9000-DC Main Cabinet

2 Specification

Hole Size Detected / Throughput	0.1mm / 140 bottles per minute / 8 heads. ¹
Number of Test Channels	1,2,3,4,5,6,8,10,12 ²
Leak Test Method	Ratiometric Pressure Decay, Auto-zero, Auto-Scale. Adaptive pressurisation algorithm.
Power Supply	24VDC
Power Consumption	50 VA maximum ³
Air Supply	60-150 psi (4-10 bar)
Air Consumption	1 litre per minute typical
Minimum Bottle Volume	250 cc
Maximum Bottle Volume	10 litres (2 gallons)
Test Pressure	Adjustable, 0.15 - 0.6 psi (10 - 40 mB)
Cycle Time	1.0 - 20.0 seconds
Transducer	Semiconductor strain gauge diaphragm, 0.00 - 65.00 mB, 0.02% resolution, x20 Over-pressure Protection.
Display	10 inch Colour IPS TFT High Brightness Industrial Display 1024x600
Touch Panel	Projected Capacitive Touch (PCT)

2.1 Performance Table

The table below is based on real-life figures as measured on a wide range of installations, machine configurations and bottle types. Realistic values are assumed for the variables involved (conveyor speed, bottle dimensions, bottle stretch characteristics, leak tester accuracy). The sensitivity shown is conservative. However, it is likely that a particular application will encounter different values for these. For example, an unstable bottle may require a slower conveyor. We suggest that you contact the office before specifying a particular model of leak tester so that we can take all parameters into account.

In Table 2.1, the throughput in bottles per minute is shown along the top. The bottle size in litres is shown at the left hand side, along with an approximate equivalent in fluid ounces. For each combination of bottle size and bottles per minute, the suggested number of test heads is given.

Table 2.1 Number of test heads required, for various container sizes and production rates (Containers Per Minute).

¹ See performance table for details.

² Specify when ordering

³ excludes conveyor

1 General Machine Operation

The leak tester is automatic in operation.

To *switch on* Proceed as follows:



- Check air applied (pressure gauge on air inlet above 4 bar).
- Check power applied (Red light on control panel)
- Ensure all emergency stops are off (pulled out).
- Press the green start button on the control cabinet. Green lamp should come on.
- Allow bottles into the leak tester.

To *Switch off*

- Press the Stop button on the control panel.

To *Verify Operation*

- If required, correct leak tester operation can be verified by passing a sample bottle with a test hole repeatedly through the leak tester, once for each channel.
- A self-test option is available that automates this process, introducing a deliberate controlled leakage and verifying successful detection.

To *Clear a Bottle Jam*

- Press the Stop button.
- Clear the leak tester area of bottles.
- Make sure the stop button is pulled back out, and then press the green start button.
- Allow bottles into the leak tester again.

2 Quick Set Guide



Ensure that the leak tester is mechanically adjusted so that the necks of the bottles are positioned centrally under the test heads during the test.

The sealing force of the test head on the bottle needs to be set. This can be done in one of two ways.

- For strong bottles, which can withstand a large toplod force, set the test head bracket so that there is approximately 10mm clearance above the bottle when the heads are up. Adjust the Test Head pressure regulator so that the test head comes down with enough force to seal on the bottle.
- Alternatively, if the bottle is extremely lightweight, turn the pressure regulator to 2 Bar. Adjust the vertical position of the test head bracket so that when the heads are down, they compress the bottle by the amount required to get a good seal.



If the required settings for the job have not yet been established, start as follows.

Press the "settings" icon on the main screen to go to the settings screen.

Test Time	1 second
Pressurize Time	1 second
Test Pressure	30 mB
Maximum Leakage	15%
Start Delay	0.75 seconds
Blowoff Time	0.10 seconds
Blowoff Delay	0.10 seconds

These are the "factory set" values and are intended as a starting point ONLY.

Set the front panel pneumatic regulators "Test Head Force", "Pressurization" and "Stop/Separate Cylinders" all to 1 bar.

Send some bottles through the leak tester and make any adjustments to the guides that are required.

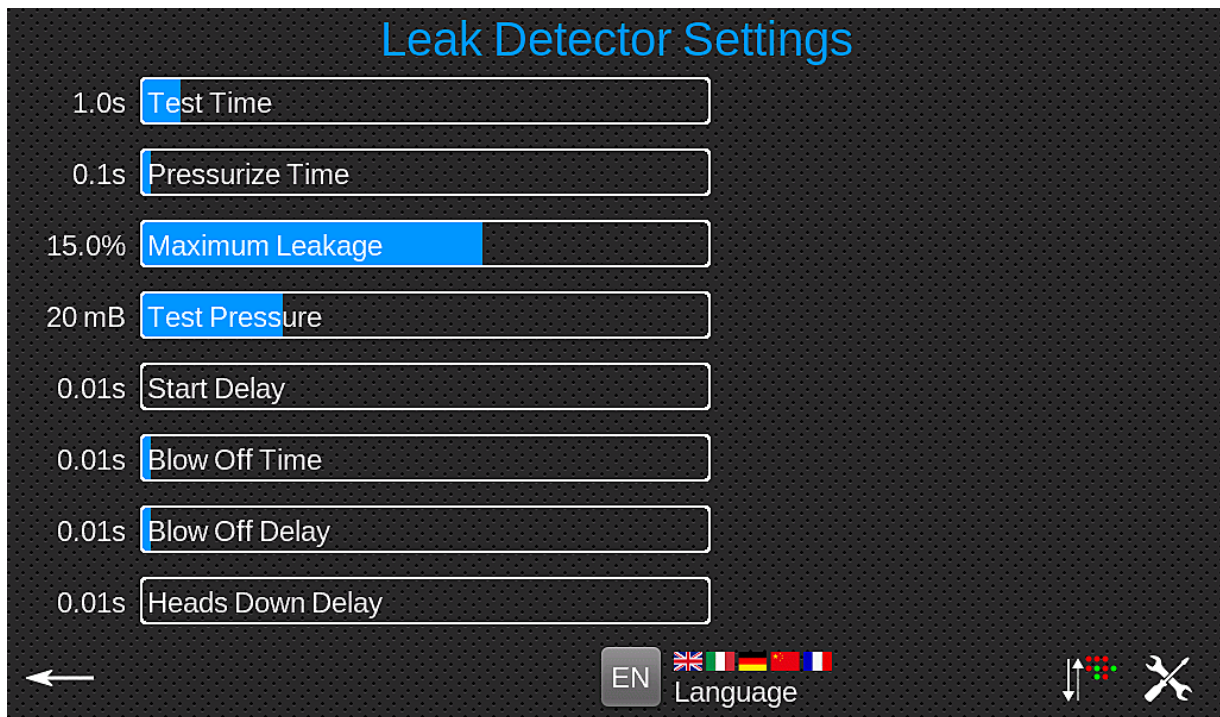

Figure 2.1 Settings Screen

Note the leakage level obtained for good bottles (on the main DISPLAYS page).

Set the "Maximum Leakage" (on the SETTINGS page) to a level slightly above this. About 2% above this is usually correct, but this will depend on the consistency of the results. For example, if good bottles are coming through with 8.0% pressure decay on average, set the Maximum Leakage to 10.0%. If the result is always between 7.5% and 8.5%, the limit can be reduced to 9.0% to improve the test sensitivity.

3 Displays and Settings

Most information is presented on the graphical touchscreen control panel. The information is organized into several pages. The pages specific to leak detector operation are explained in this section; other pages may be available depending on the options installed. These are discussed in the relevant sections of the manual.

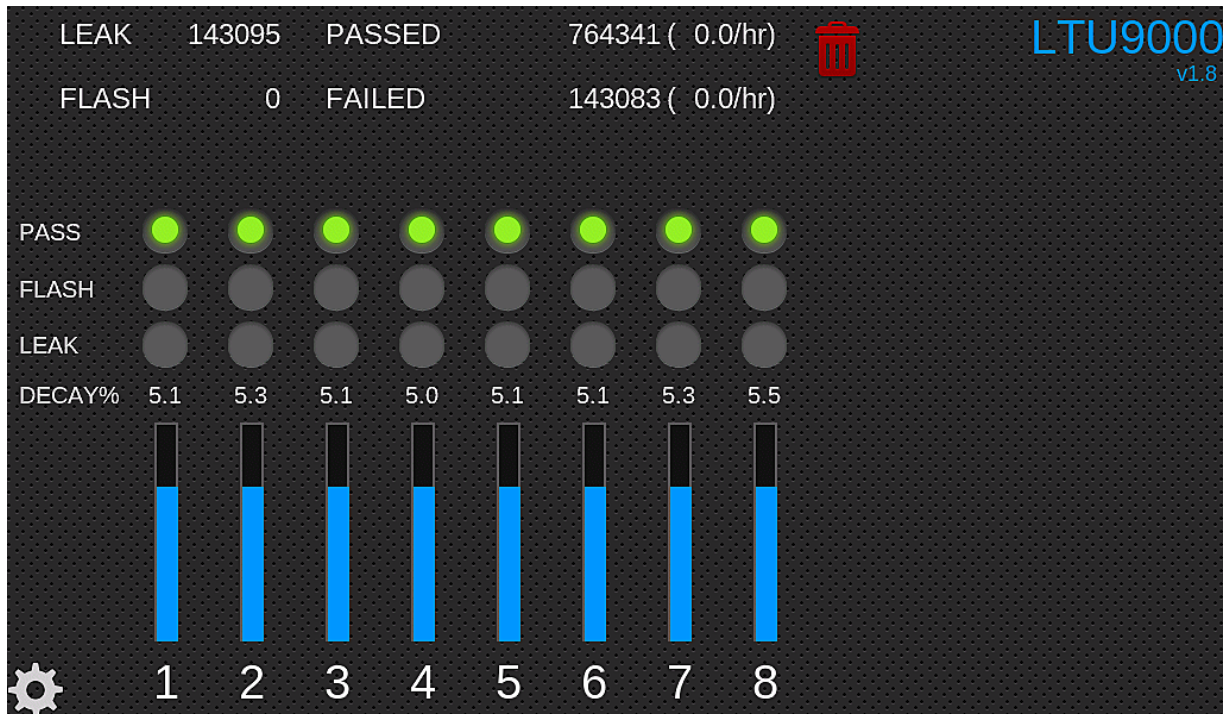
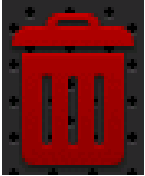

Figure 3.1 The main page displayed during operation

3.1 Displays

This is the main page displayed during normal running. The system will always show this page after power-on.

This page displays the following information:



Counts

These are counts of the number of bottles that have passed and failed the tests. There are also hourly rates of these displayed. The counts can be cleared by pressing the "trash" icon:

3.1.2 Pressure Scales



A pressure scale is displayed, in bar graph form, for each channel. This gives a quick visual indication of the actual pressure in the bottle at any instant in time. The display is scaled to the set test pressure, so that full scale always equals the set test pressure.

3.1.3 Test Result Indicator



Above each pressure scale are indicator lights, which show the test results.

3.1.4 Leak%

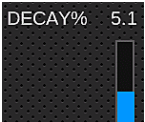

Each test head has a display of a number representing the precise result of the leak test. The number displayed is the percentage of the initial pressure which has been lost during the test. This number is compared against the set limit ("Maximum Leakage") to determine pass or fail.

3.1.5 Production Rate

This shows the throughput of the leak tester in Bottles Per Hour. This is updated every cycle but averaged over several.

3.2 Leak Test Settings

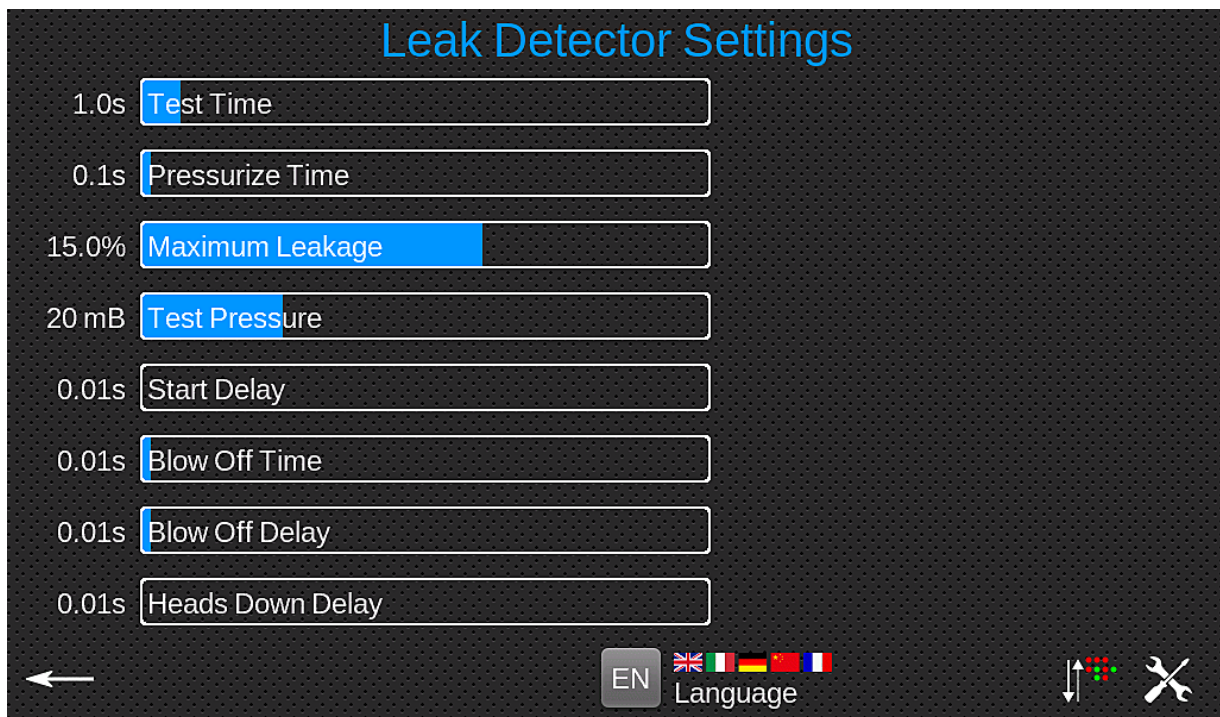
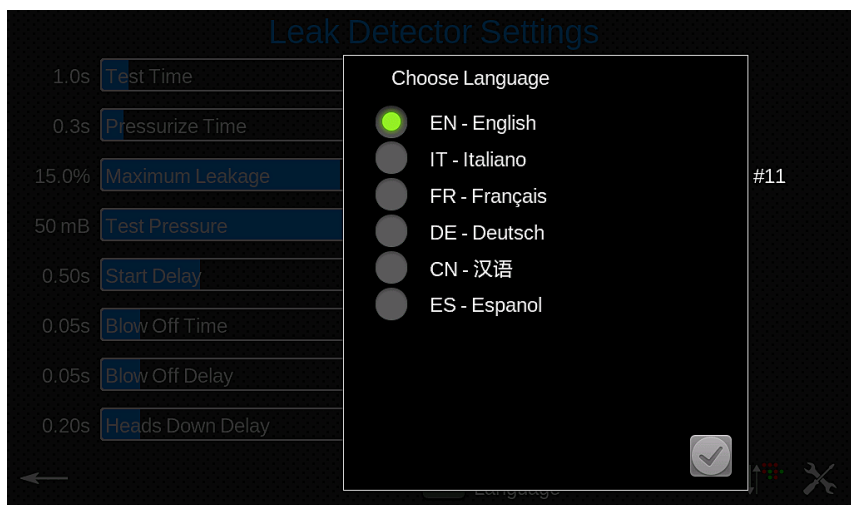

Figure 3.2 LTU9000-DC Settings

To change a setting, touch the slider and move it to the desired value.

- | | |
|-----------------|---|
| Test Time | Controls the length of the leak test. The higher this setting, the more accurate the leak test. This should be set to as high a value as possible, consistent with bottle throughput. |
| Pressurize Time | Sets the maximum time for which the leak tester will attempt to pressurize a bottle under test. 1 second is normally sufficient. This can be reduced in order to reduce the overall cycle time, if required. If it is reduced too far, the machine will not have enough time to pressurize the bottles and they will be rejected. |
| Maximum Leakage | Sets the sensitivity of the test. The percentage of pressure decay measured by the test is compared with this value to determine the test result. If the decay is greater than this value, the bottle is rejected. |

Test Pressure	The target pressure used to inflate the bottle. A value of 20mB is typical. Higher values can give marginally more accurate results but may distort the bottle during the test.
Start Delay	The test cycle is started when a stationary bottle is detected at test station. The time for which the bottle must be stationary can be adjusted using this setting. A higher value prevents false starts due to a very slow conveyor, and allows time for the bottles to stabilize before the heads are brought down.
Blowoff Time	This sets the length of the pulse of air, which is used to reject the bottles. This can be adjusted to provide accurate control of the force required.
Blowoff Delay	This sets the delay after triggering the reject photoswitch, before the air jet starts. This can be used to fine-tune the direction of bottle blow-off. (So that the bottle can be cleanly knocked out of a group of bottles).
Heads Down Delay	This sets the delay before the test heads come down on the bottles. This allows time for the bottles to come to a stable position.
Language	Shows the language chooser dialog.



3.3 I/O Screen

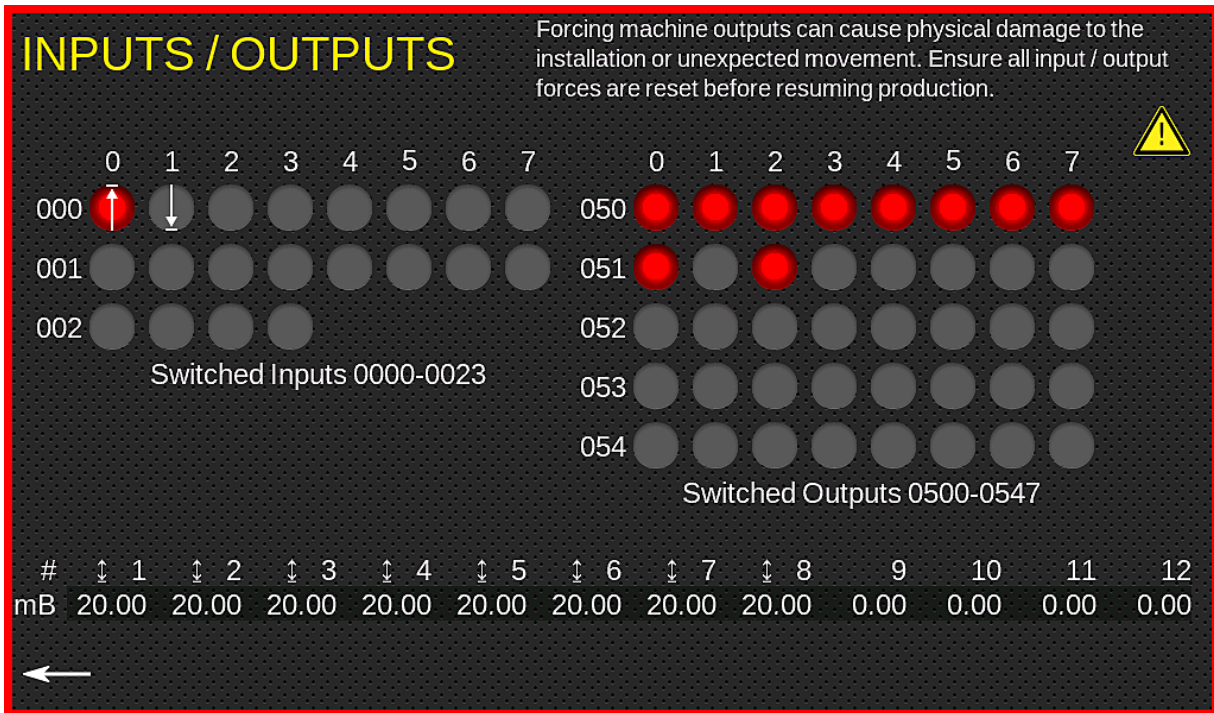

Figure 3.3

See the Machine Input / Output Sheet for details of the function of each input and output.

The state of each I/O is shown by an indicator being lit (for on) and unlit (for off).

The inputs are shown in the top left these are number 0000 to 0023.

The outputs are shown top right these are 0500 to 0547.

The bottom row shows the pressure transducer outputs as digital values. These are in mB (millibar).

3.3.1 Forcing

Please note the forcing machine outputs can cause physical damage to the machine or unexpected movement. Ensure all input/output forces are reset before resuming

production.

The state of an output or input can be over-ridden from this page as follows:



- Touch the indicator corresponding to the input or output which requires forcing. It will highlight with a blue square.



- Some buttons appear to control the I/O.



- To force on, press the "up arrow". The indicator will include an emblem to show it is forced on.



- To force off, press the "down arrow". The indicator will include a "forced off" emblem. .



- To reset to normal operation, press the "Reset" red cross.'.

Ensure that no I/O's are left forced to 0 or 1 when normal operation is to be resumed. If in doubt, power-off and on to reset the system.

4 Principle of Operation

The test cycle is normally initiated by a signal from the Test Station Photoswitch. The test head cylinder valve is turned on, bringing the test head down to seal on the bottle. At the same time, the pressurization valve is turned on, allowing the bottle to pressurize. When the pressure in a bottle rises past a threshold, the pressurization valve is turned off. After a short delay, the pressure in the bottle is measured (Pressure A). The bottle remains sealed for the remainder of the test time. At the end of the test, the pressure in the bottle is again measured (Pressure B). The test head is then retracted. The percentage of pressure decay is then calculated from the two pressure measurements. This is the result of the test. This is compared with the set limit and a pass/fail decision made.

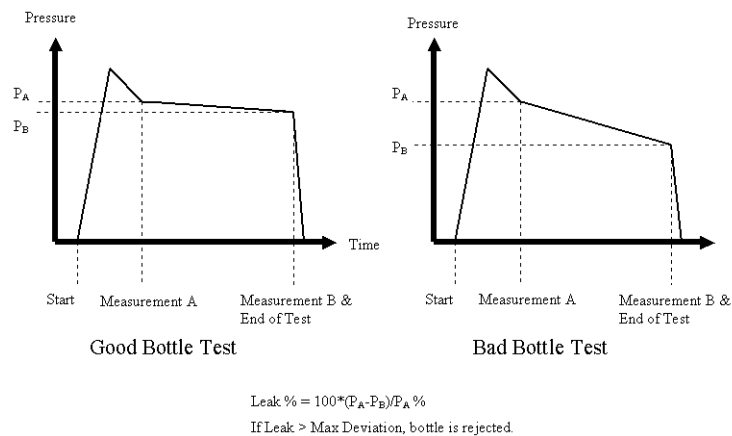

Figure 4.1 Pressure Decay Leak Detection Operating Principle

There are other checks made in order to catch exceptional conditions. For example, we reject the bottle if

- There is insufficient initial pressurization.
- The bottle collapses during the test, creating a pressure rise.

Also not shown is the automatic tuning of the pressurization valves, which removes the need for individual manual flow control adjustments on each test channel.

5 Installation

Plastech Control Systems, or our representatives normally perform installation. However, some guidelines are here provided for customers who wish to do this themselves. Contact us (or our representatives) directly for more detailed information and advice.

We assume here an installation on a pre-existing conveyor system; this is the typical case.

5.1 Initial Specification of Equipment

The customer should have specified the following information

- Supply voltage
- Number of test heads
- Right or left handed operation (do the bottles come from the right, or the left, as viewed from in front of the main control panel).

5.2 Conveyor

We recommend that a variable speed drive be fitted to the conveyor, so that bottle transport can be optimized. In general, the conveyor should be run as fast as possible while maintaining bottle stability, and taking into account other equipment on the line.

5.3 Location

Typically there will be a blow-molding machine, a conveyor system and a packaging machine or station at the end of the conveyor. The packaging system, such as a bagger or collating table, may have periods when bottles are not being removed from the conveyor (for example, when a pack is completed). This will cause a temporary queue to form.

In general, for a variety of reasons, the leak detector should be situated as far downstream as possible, away from the blow-molding machine. This is so that the operator has the maximum amount of time to clear any problems (jams, etc.), before the leak tester infeed queue backs up into the blow molder. However, if there is any downstream equipment which generates a periodic queue, such as the bagger mentioned above, then the length of the queue should be established and the leak tester sited upstream of it.

5.4 Installation Layout

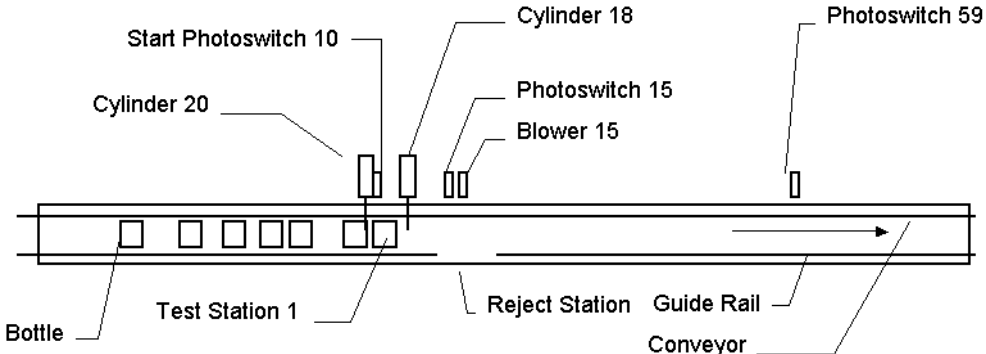

Figure 5.1 Single Channel, Left Handed Installation

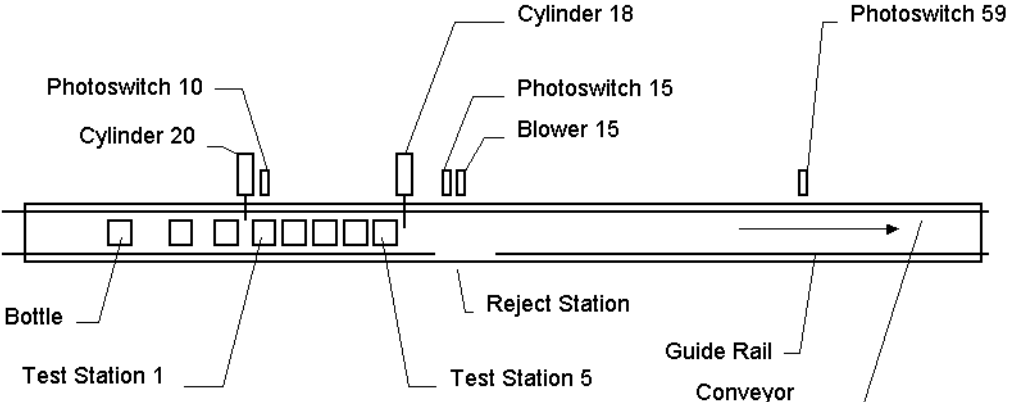

Figure 5.2 Multi Channel, Left Handed Installation (2-12 heads)

5.5 Mounting

Mount the main cabinet under the conveyor. It is usually most convenient to bolt the top to the conveyor frame, with one side bolted to a conveyor support leg.

Mount the test head frame above the control cabinet.

The existing guides are normally run straight through the test area, however these need to be cut at the reject station. The gap needs to be much more than the width of a bottle, since the bottle will be moving along during rejection. Often it is best to only cut the top rail (of 2), with the bottle being blown over the top of the bottom rail. The reject station is normally immediately after the test station.

Refer to the layout diagram for an outline of the main items. The leak tester can be used with the bottle stream coming either from the left, or from the right, as viewed from in front of the control cabinet. However, the correct program needs to be installed (right or left handed).⁴

5.6 Supplies

5.6.1 Electrical

The system operates from a 24V DC supply only. Do not connect to mains voltage.

The control cabinet frame must be securely earthed using the stud provided, next to the isolator.

5.6.2 Pneumatic

The system requires clean, dry air at 4-10 bar. We provide a 1/4 inch BSP air inlet for the connection.

⁴ We do not currently make this user selectable, since an incorrect setting would result in apparently correct operation except that the wrong bottle would be rejected!

5.7 Piping

The valve manifold should be clearly labeled with the function of each valve; so piping up the machine⁵ should be straightforward.

Please refer to Figure 5.3 showing a typical valve manifold. The basic design is the same with variations for number of test heads and extra functions on particular models.

Some notes follow:

Check that the correct program has been supplied (right or left handed, see "Initial Specification" above).

Each test head has two pipes going into it, ``sense'' and ``pressurization''. The top valve is the pressurization valve for test head 1. This is *always* the left hand test head, as viewed when in front of the control cabinet. The sense pipe from this left hand test head always goes to the left hand pressure transducer on the circuit board, via the bulkhead fittings on the top face of the control cabinet. It is very important that pressurization and sense pipes are correctly paired, since an error here will result in inconsistent pressurization of the bottles. This can be difficult to diagnose.

Make sure that piping is done with the test heads set to representative positions, and that there is enough slack to accommodate the full range of bottles that will be used with this machine.

5.8 Photoswitches



The usual sensors supplied are visible light, diffuse reflective, self tuning, background suppression types. Connect these according to the wiring diagram and I/O list for your machine (see Page 33). The two most important ones are shown in Table 5.1.

The START photoswitch is mounted so that it sees the last bottle to enter the test area, before cycle start. Cycle start is triggered by the start photoswitch being on for longer than the set Start Delay.

The REJECT photoswitch is mounted just before the reject blower.

⁵ Most pneumatic piping is now done before delivery of the machine, however we have left this section in the manual for reference.

- F1 / PRESSURIZE 1
- F2 / PRESSURIZE 2
- F3 / PRESSURIZE 3
- F4 / PRESSURIZE 4
- F5 / PRESSURIZE 5
- F6 / PRESSURIZE 6
- F9 / PRESSURIZATION
INLET [P]
- F10 / TEST HEADS DOWN
- F15 / REJECT
- F40 / SYSTEM PRESSURE [P]
& RETURN [R] &
PILOT SUPPLY [X] &
EXHAUST [PE]
- F17 / STOP
- F20 / SEPARATOR
- F107 / BOTTLE STOPS
INLET[P] + RETURN[R]
- OPTION (EXAMPLE)
- F40 / SYSTEM PRESSURE



Figure 5.3 Pneumatic Valve Manifold Example Layout (6-Head)

<i>Terminal</i>	<i>Name</i>	<i>Colour</i>	<i>Sensor</i>	<i>Function Number</i>
000+	+24V	Brown		
000	Signal	Black	START	10
000-	0V	Blue		
001+	+24V	Brown		
001	Signal	Black	REJECT	15
001-	0V	Blue		

Table 5.1 Photosensor Wiring

An optional downstream queue photoswitch is mounted downstream of the test area. If it is blocked at the end of the test, then the bottles are not released and the leak tester will halt until it is clear.

All these photoswitches should be positioned so as to see the gaps between the bottle necks, even when the bottles are touching.

5.9 Testing

Correct installation should be checked, not initially by testing bottles but instead by systematically going through the I/O list and checking each function. This is important because some piping mistakes can result in apparently correct operation that is in fact unreliable.

Go through the I/O list for your machine (see table 9.1 on page 33). From the front panel, force each one on and off in turn, and check that the correct machine function operates.

When I/O testing is finished, power off the leak tester for a few seconds, to release any forced outputs.

5.9.1 Pressurization

Do not force on the pressurization valves when the test heads are down on a bottle, since this will result in an uncontrolled over-pressurization that may

damage the transducers.

Pressurization valve 1 (Output 500) should be the test head closest to the reject station.

Note: The pressurization and test head up/down will not operate unless the front panel pressure regulators have been set to non-zero!

5.9.2 Test Head Up/Down

Check that this operates on the appropriate output number (see table 9.1 on page 33) and set the front panel regulator as required. All heads should move up and down smoothly, together.

5.9.3 Function Valves

Check the other fitted functions as per the I/O table.

5.9.4 Transducers

Correct transducer piping can be checked as follows:

- Force the stop cylinder out
- Line up the appropriate number of bottles under the heads
- Force the test heads down
- Manually squeeze the bottles one by one. You should see pressurization on the appropriate bargraph. Bargraph 1 should be the left hand head, corresponding to pressurization valve 1.

Proceed by following “Quick Set Guide” on page 14.

6 Battery

The LTU9000-DC has a lithium coin cell on circuit board behind the touch screen.

It is used to power the memory that stores the on-screen counts. It is not required to maintain the main machine settings or to operate as a leak tester.

The battery has a life of about 5 years unpowered.

If the battery becomes exhausted then the count values will be lost.

If this happens then the battery needs to be replaced.

The type is ``CR2032 lithium coin cell''.

It is a very common size that should be available in most electronics stores etc. Of course we can supply replacements too.

After the new battery is fitted the counts can be reset.

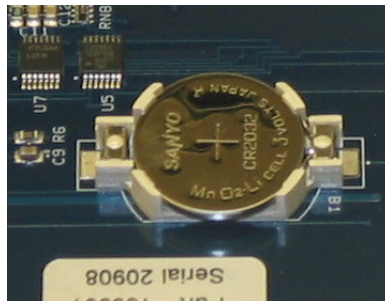

Figure 6.1 CR2032 Lithium Coin Cell

The LTU9000-DC can be used for leak detection indefinitely even with a low battery. However the counts will not be retained after a power-off.

7 Component Numbering Scheme

The drawings following show the layout and interconnections of the various components, electrically, pneumatically and mechanically. The component numbering system is not obvious and requires explanation.

The heart of the machine is an electronic control system with various inputs and outputs (I/O's). There are a fixed number of these for any given installation (although extra I/O's can be added). These I/O's are connected to various devices (photoswitches, valves, cylinders motors etc), which make the machine work. A controller program reads the inputs and controls the outputs according to its program. The controller card I/Os have a fixed numbering system, with inputs starting at 0000, 0001, 0002 etc and outputs starting at 0500,0501,0502 etc. The I/O's are labeled in this way on the circuit card LED's, also on the I/O page of the machine display. The function of a particular I/O number may be different depending on the configuration of machine supplied. There are so many options and configurations that it would be very wasteful to dedicate an I/O for the same function on all machines. Instead, the controller program for a particular machine configuration allocates I/O's, more or less sequentially.

To avoid having to make individual electrical, pneumatic and layout drawings for each machine combination, Universal Function Numbers have been defined. I/O numbers are related to Function Numbers by a single table in the product manual. Function specific parts (e.g. the Test Head Cylinder) are given a number according to that function (in this case, Cylinder 10). This will be the same in any PCS product that has a Test Head Cylinder; it will always be Cylinder 10, CYL10 etc. The photoswitch that actuates the test head could also be called Photoswitch 10, PS10, etc. The actual I/O number can vary between machine types (although will be the same for two machines of the same model)

8 Function Number Cross-Reference

ID	Description				
1	Pressurization Channel 1	37	Blocked Bore Channel 2	75	Lock Settings
2	Pressurization Channel 2	38	Bottle Support	76	FallenSenseTop
3	Pressurization Channel 3	40	System	77	FallenSenseBottom
4	Pressurization Channel 4	41	Emergency Stop	78	FallenSenseEject
5	Pressurization Channel 5	42	Safety OK	79	SupportPlate
6	Pressurization Channel 6	43	Power On	80	Alignment Plate
7	Pressurization Channel 7	44	Machine Run	81	Holding Moulds
8	Pressurization Channel 8	45	Machine Stop	82	Box Inverter
9	Pressurization	46	Alarm	83	Machine Reset
10	Test Heads Down	47	Motor Tacho	84	Test Pass
11	Test Head Down Channel 1	48	Test A	85	Test Fail
12	Test Head Down Channel 2	49	Turner Downstream Stop	86	Vent
13	Test Head Down Channel 3	50	Turner Upstream Stop	87	Seal Neck
14	Test Head Down Channel 4	51	Test B	88	Seal Aux
15	Reject	52	Update Data	89	Leak Tester Self Test
16	Leak Test Reject	53	Unused I/O	90	Pressurization Channel 9
17	Leak Test Bottle Stop	54	Reject Channel 1	91	Pressurization Channel 10
18	Leak Test Bottle Stop 1	55	Reject Channel 2	92	Pressurization Channel 11
19	Leak Test Bottle Stop 2	56	Reject Channel 3	93	Pressurization Channel 12
20	Leak Test Bottle Separator	57	Reject Channel 4	94	Pressurization Channel 13
21	Conveyor Merge Gate	58	Short Row Stop	95	Pressurization Channel 14
22	Brush	59	Downstream Backup	96	Pressurization Channel 15
23	Infeed Conveyor	60	Diverter Mechanism	97	Pressurization Channel 16
24	Indexing Conveyor	61	Leak Test Infeed Brake	98	Flash Detection 1
25	Turner	62	Diverter Gate Infeed Brake	99	Flash Detection 2
26	Turner Queue Brake	63	Diverter Gate 1	100	Flash Detection 3
27	Collating table Infeed Stop	64	Diverter Gate 2	101	Flash Detection 4
28	Carriage Up	65	Diverter Gate 3	102	Flash Detection 5
29	Carriage Down	66	Main Drive	103	Flash Detection 6
30	Carriage Forward	67	Blower	104	Flash Detection 7
31	Carriage Back	68	Fan	105	Flash Detection 8
32	Carriage Up-Down	69	Busy	102	Flash Detection 9
33	Carriage Forward-Back	70	Cycle Start	103	Flash Detection 10
35	Flash Detection	71	Ready	104	Flash Detection 11
36	Blocked Bore Channel 1	72	Start 1	105	Flash Detection 12
		73	Start 2	106	Bottle Dump
		74	Index Position	107	Bottle Stops

9 Input / Output Listing

Table 9.1 shows the input and output allocations for the standard LTU9000-DC range of leak testers. This can be used to trace the operation when fault finding or installing the system.

9.1 Notes

- Special Inputs - Some special options may cause the I/O allocation to differ from that shown. Contact Plastech Control Systems for information on your specific configuration.
- Divertor Gate Infeed Brake - Shares function with Downstream Backup Sensor since would not normally have both.
- ``Flash Detection`` inputs also used for choked bore detection.

<i>Function</i>	<i>Name</i>	<i>-1</i>	<i>-2</i>	<i>-3</i>	<i>-4</i>	<i>-5</i>	<i>-6</i>	<i>-8</i>	<i>-10</i>	<i>-12</i>	<i>Others</i>
Standard Inputs											
10	Test Heads Down										000
15	Reject										001
59	Leak Test Downstream Backup										002
61	Leak Test Infeed Brake										003
Standard Outputs											
1	Pressurization Channel 1	500	500	500	500	500	500	500	500	500	
2	Pressurization Channel 2		501	501	501	501	501	501	501	501	
3	Pressurization Channel 3			502	502	502	502	502	502	502	
4	Pressurization Channel 4				503	503	503	503	503	503	
5	Pressurization Channel 5					504	504	504	504	504	
6	Pressurization Channel 6						505	505	505	505	
7	Pressurization Channel 7							506	506	506	
8	Pressurization Channel 8								507	507	
90	Pressurization Channel 9									510	
91	Pressurization Channel 10									511	
92	Pressurization Channel 11										512
93	Pressurization Channel 12										513
10	Test Heads Down	501	502	503	510	510	510	510	514	514	
15	Reject	502	503	504	511	511	511	511	515	515	
17	Leak Test Bottle Stop	503	504	505	512	512	512	512	516	516	
20	Leak Test Bottle Separator	504	505	506	513	513	513	513	517	517	
19	Leak Test Bottle Stop 2		505	506	514	514	514	514	520	520	
61	Leak Test Infeed Brake										515
Special Inputs											
62	Diverter Gate Infeed Brake										002
76	Fallen Bottle Sense Top										012
77	Fallen Bottle Sense Bottom										013
98	Flash Detection 1										004
99	Flash Detection 2										005
100	Flash Detection 3										006
101	Flash Detection 4										007
Special Outputs											
23	Conveyor Run Relay								546	546	526
62	Diverter Gate Infeed Brake								521	521	516
63	Diverter Gate 1								522	522	517
64	Diverter Gate 2								523	523	520
65	Diverter Gate 3								524	524	521
89	Self Test								525	525	522
78	Fallen Bottle Eject								526	526	523
106	Bottle Dump								527	527	524

Table 9.1 LTU9000-DC Inputs and Outputs

10 Schematics

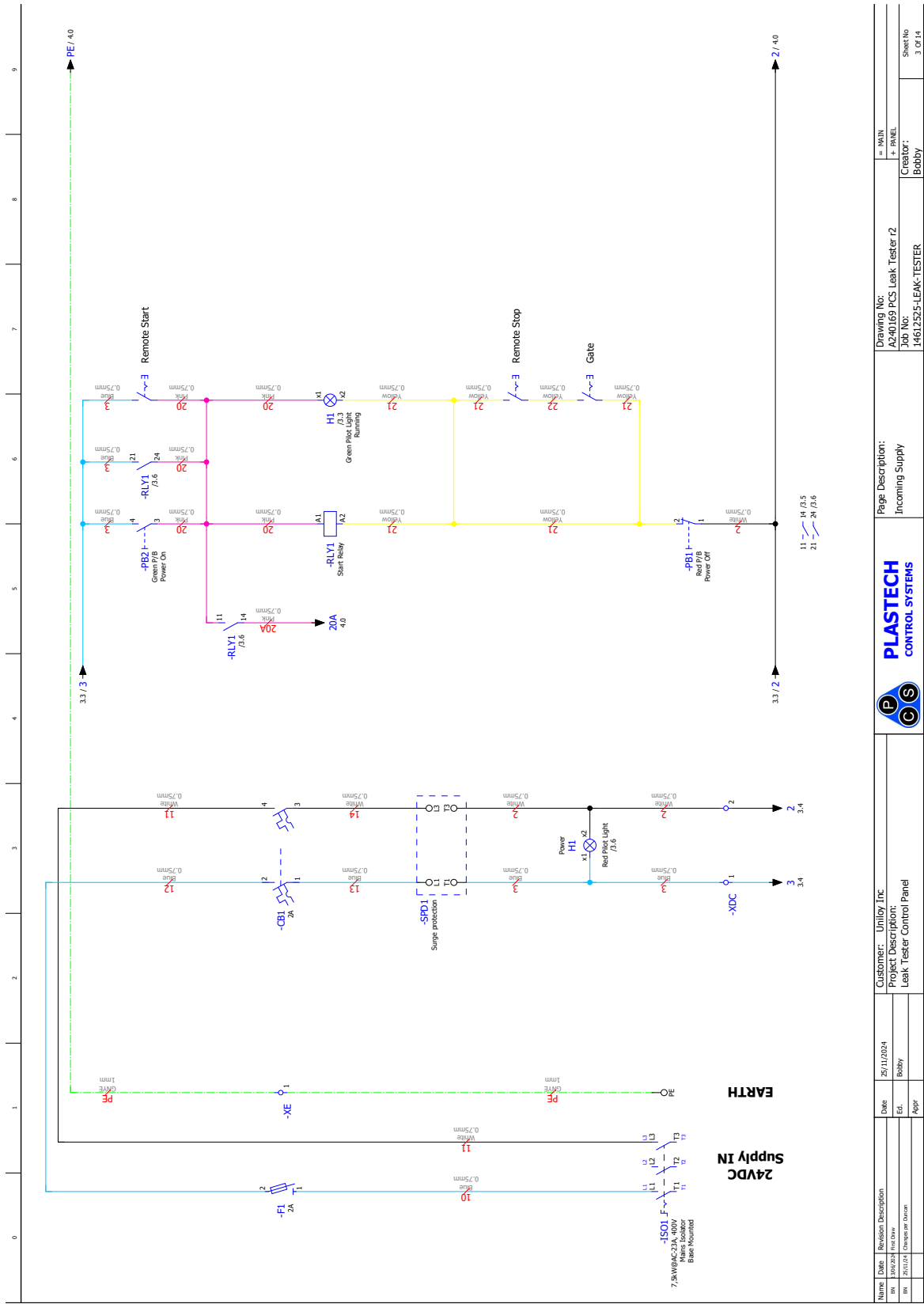

Name	Revision Description	Date	26/11/2024	Customer:	Umiloy Inc.	Page Description:	Incoming Supply	Drawing No:	AZ40169 PCS Leak Tester r2	# MAIN	
EN	14/02/24 final Draw	Ed:	Bobby	Project Description:	Leak Tester Control Panel			Job No:	14612525-LEAK-TESTER	# PANEL	
EN	25/11/24 Complete Draw	Appr:						Creator:	Bobby		Sheet No
											3 of 14



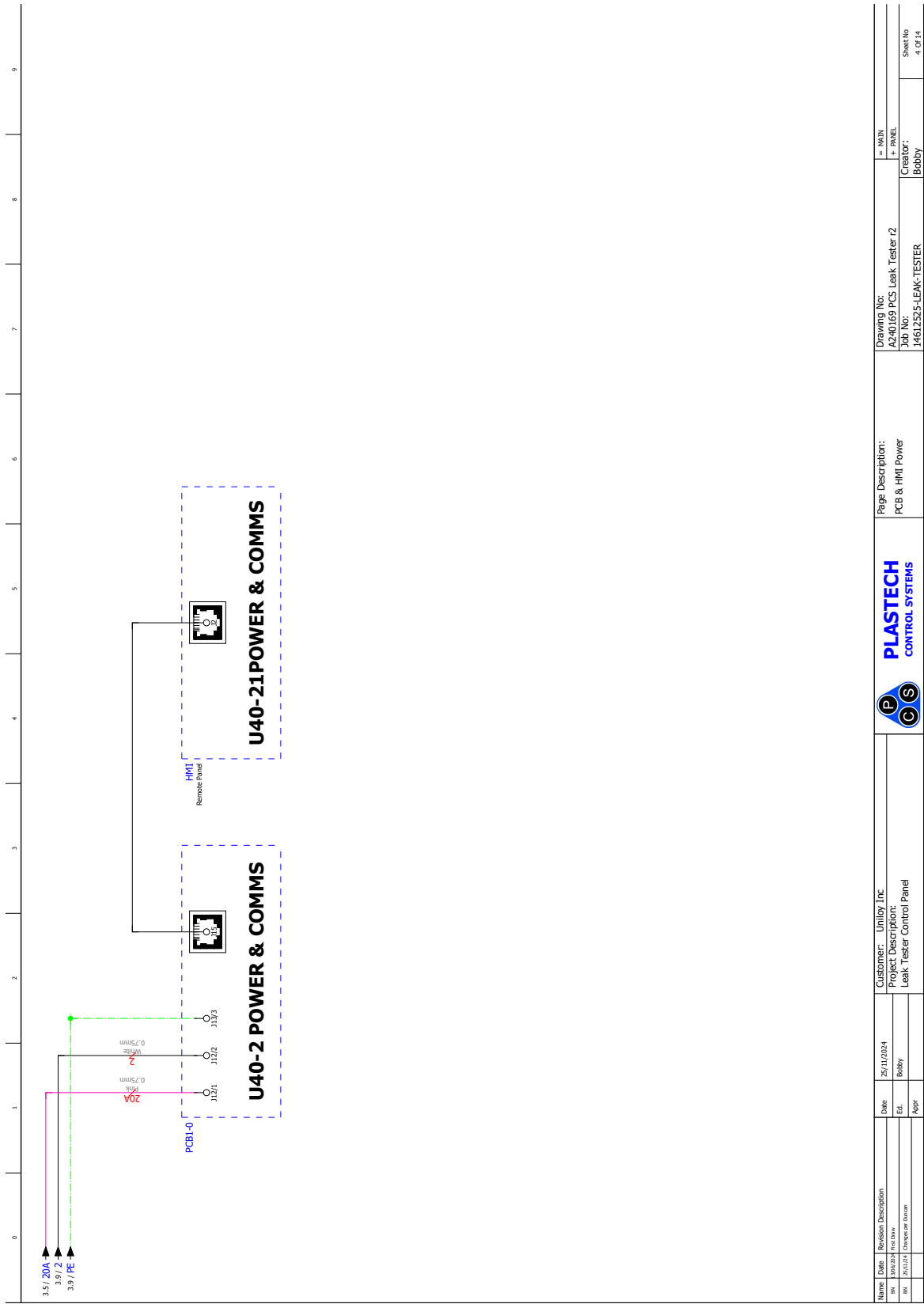

Name	Date	Revision Description	Date	26/11/2024	Customer: Uniloy, Inc.	Page Description:	Drawing No:	= MAIN
BR	25/11/24	Final Draw	Edt	Bobby	Leak Tester Control Panel	PCB & HMI Power	AZ40169 PCS Leak Tester r2	# PANEL
BR	25/11/24	Complete Draw	Appr				Job No:	Creator:
							14612525-LEAK-TESTER	Bobby
								Sheet No
								4 OF 14



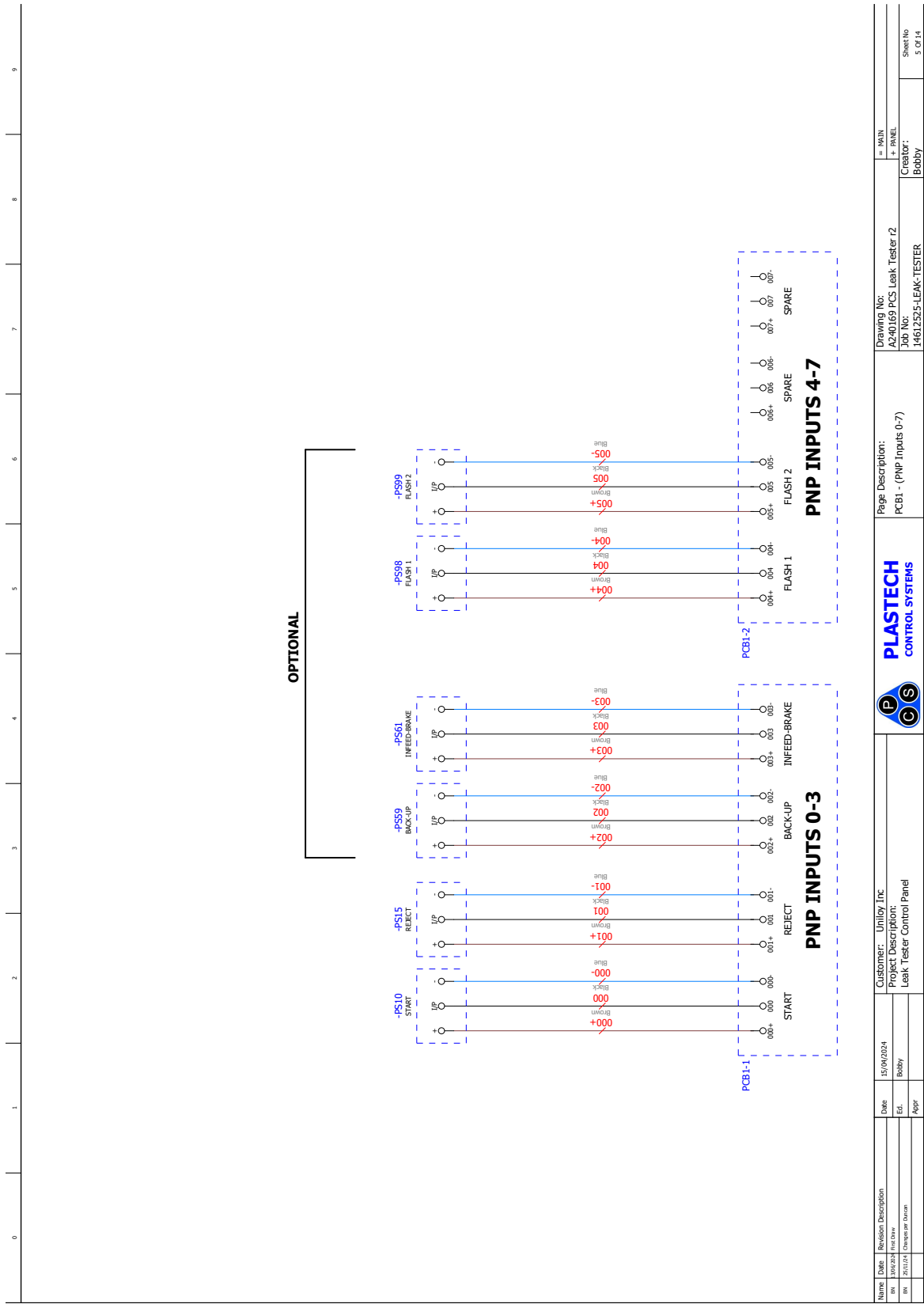

Name	Date	Revision Description	Customer:	Uniloy, Inc.	15/09/2024
BN		Initial Function	Project Description:	Leak Tester Control Panel	
BN		Initial Change per drawing	Customer:	Uniloy, Inc.	
			Ed:	Bobby	
			Appr:		
Page Description:			PCB1 - (PNP Inputs 0-7)		
Drawing No:			AZ40169 PCS Leak Tester r2		
Job No:			14612525-LEAK-TESTER		
Creator:			Bobby		
Sheet No:			5 of 14		



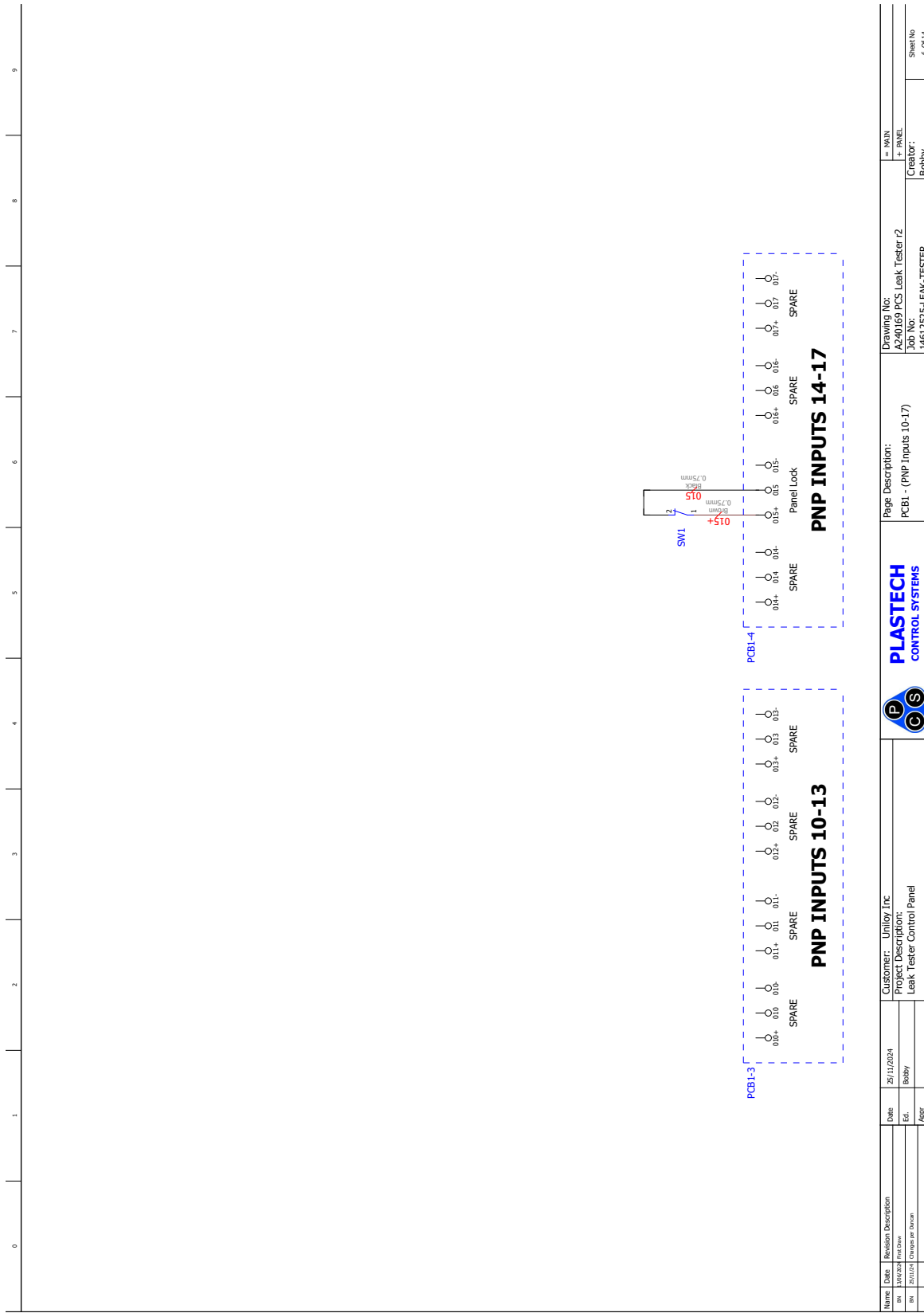

Name	Revision Description	Date	26/11/2024	Customer: Umiloy, Inc.	Page Description:	Drawing No:	= MAIN
BN	Initial Rev Desc	Edt	Bobby	Project Description:	PCB1 - (PNP Inputs 10-17)	AZ40169 PCS Leak Tester r2	# PANEL
BN	25/11/24 Change per drawing	Appr		Leak Tester Control Panel	Job No:	14612525-LEAK-TESTER	Creator:
							Bobby
							Sheet No
							6 of 14



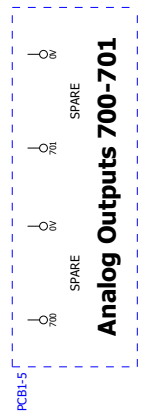
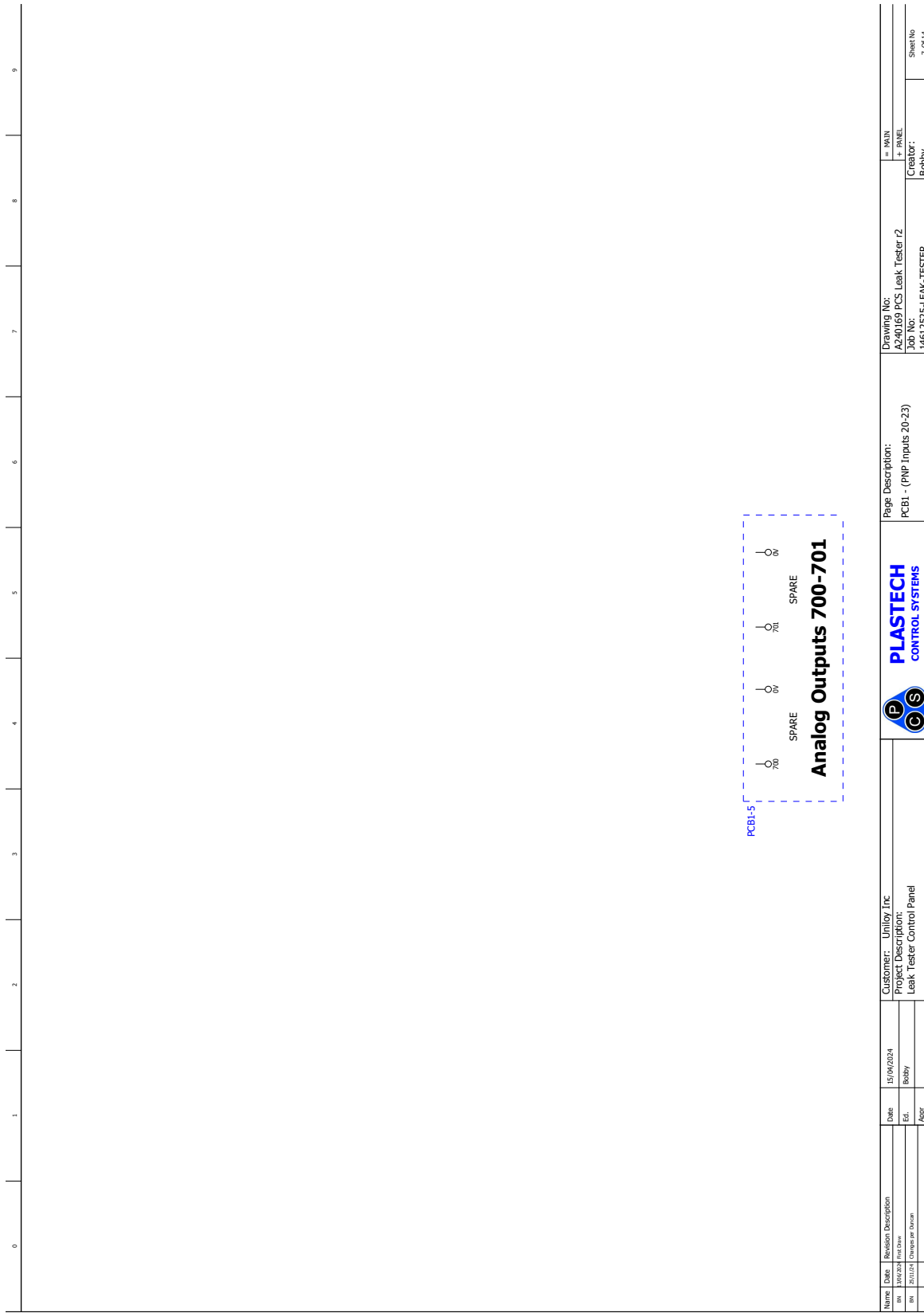

Name	Revision Description	Date	15/09/2024	Customer:	Umiloj, Inc.	Page Description:	PCB1 - (PNP Inputs 20-23)	Drawing No:	AZ40169 PCS Leak Tester r2	Sheet No	7 of 14
EN	Initial Function	Edt	Bobby	Project Description:	Leak Tester Control Panel	Job No:	14612525-LEAK-TESTER	Creator:	Bobby		
EN	Initial Change per drawing	Appr									



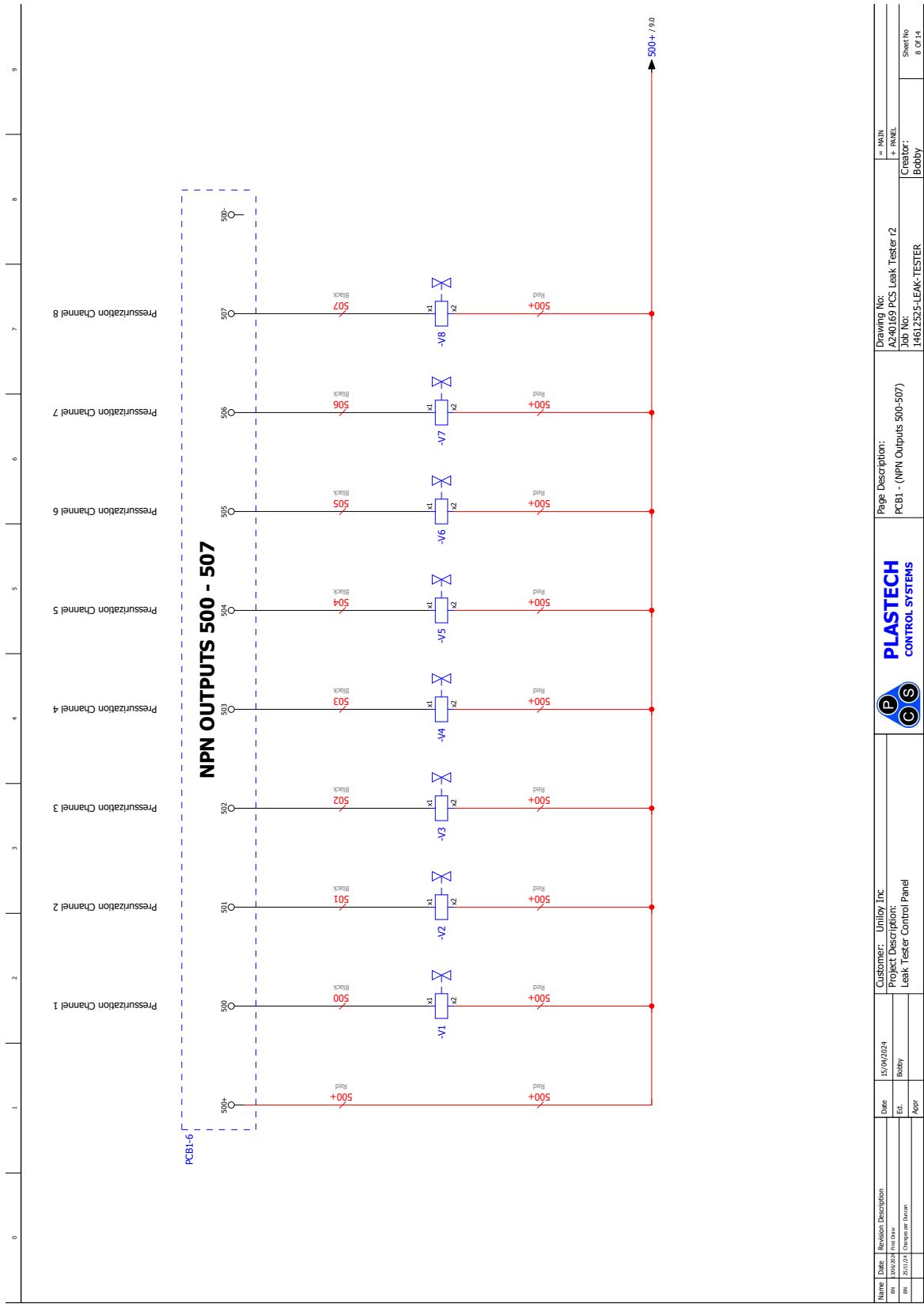

Name	Revision Description	Date	15/09/2024	Customer:	Umiloy, Inc.
BN	Initial Rev. Draw	Ed.	Bobby	Project Description:	Leak Tester Control Panel
BN	2024/04/04 Change per drawing	Appr.		Page Description:	PCBI - (NPN Outputs 500-507)
				Drawing No:	AZ-40169 PCS Leak Tester r2
				Job No:	14612525-LEAK-TESTER
				Creator:	Bobby
				Sheet No:	8 of 14



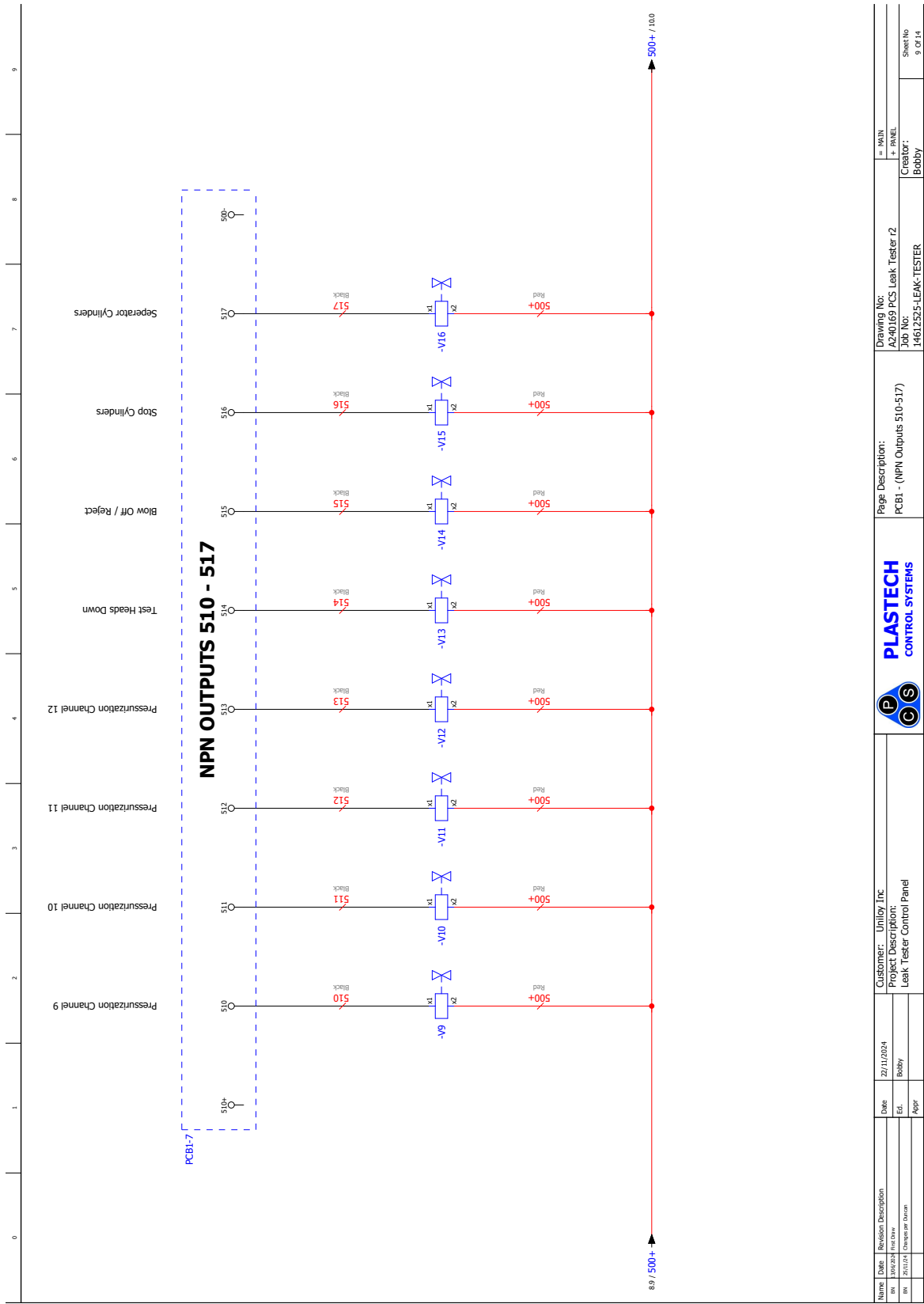

Name	Date	Revision Description	Date	Customer	Unitloy, Inc.
BN	2/11/2024	Initial Function	22/11/2024	Customer: Unitloy, Inc.	
BN	2/11/24	Change per drawing	Bobby	Project Description: Leak Tester Control Panel	

Page Description:	Page No.	Sheet No.
PCBI - (NPN Outputs 510-517)	14612525-LEAK-TESTER	9 of 14

Drawing No:	Job No:	Creator:
AZ-40169 PCS Leak Tester r2	14612525-LEAK-TESTER	Bobby

Symbol	Description
■	MAIN
■	PANEL

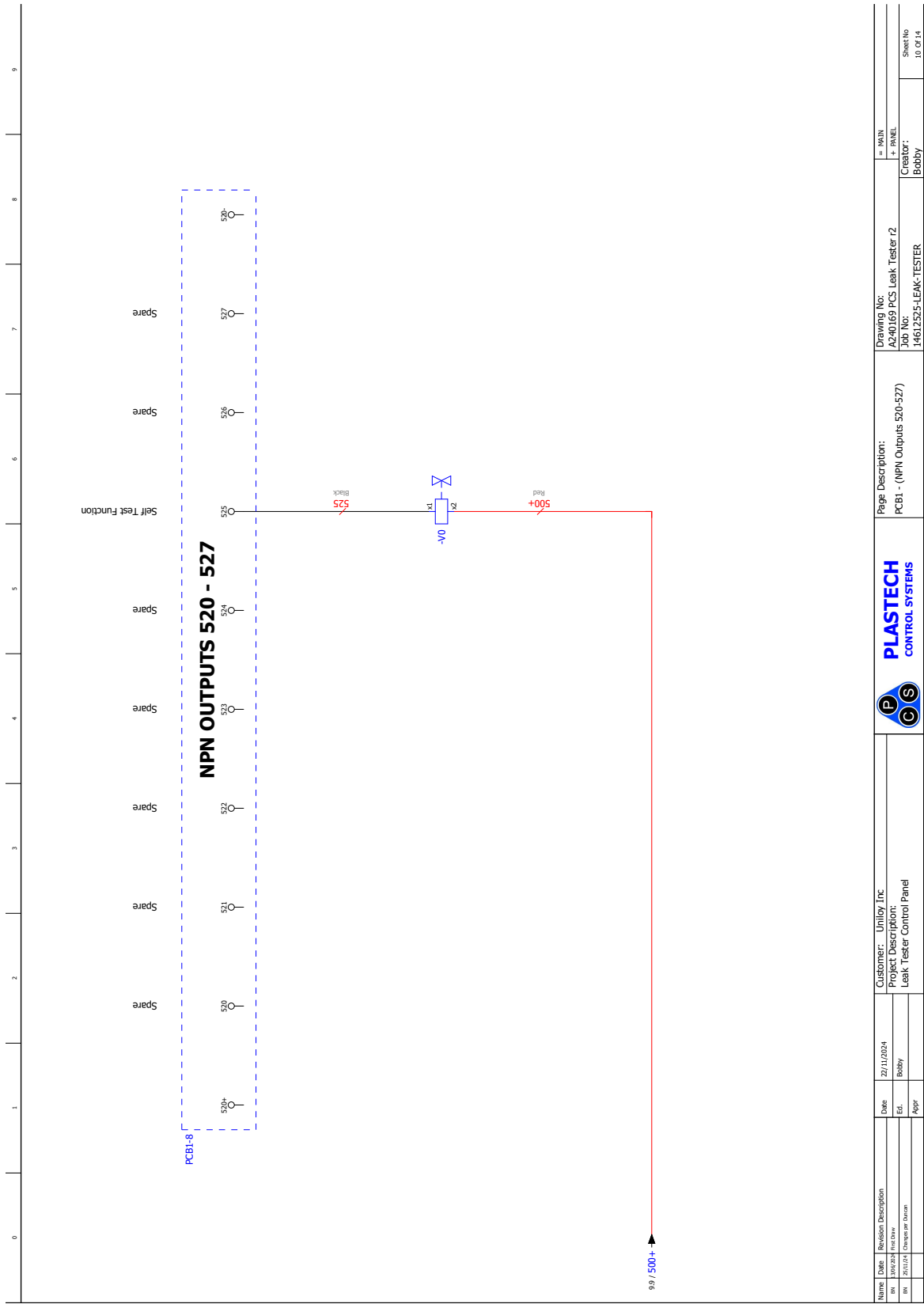

Name	Revision Description	Date	22/11/2024	Customer:	Umiloy, Inc.	Drawing No:	AZ-40169 PCS Leak Tester r2	= MAIN
BN	Initial Function	Ed:	Bobby	Project Description:	Leak Tester Control Panel	Job No:	14612525-LEAK-TESTER	# PANEL
BN	22/11/24 Change per drawing	Appr:				Creator:	Bobby	Sheet No
								10 OF 14



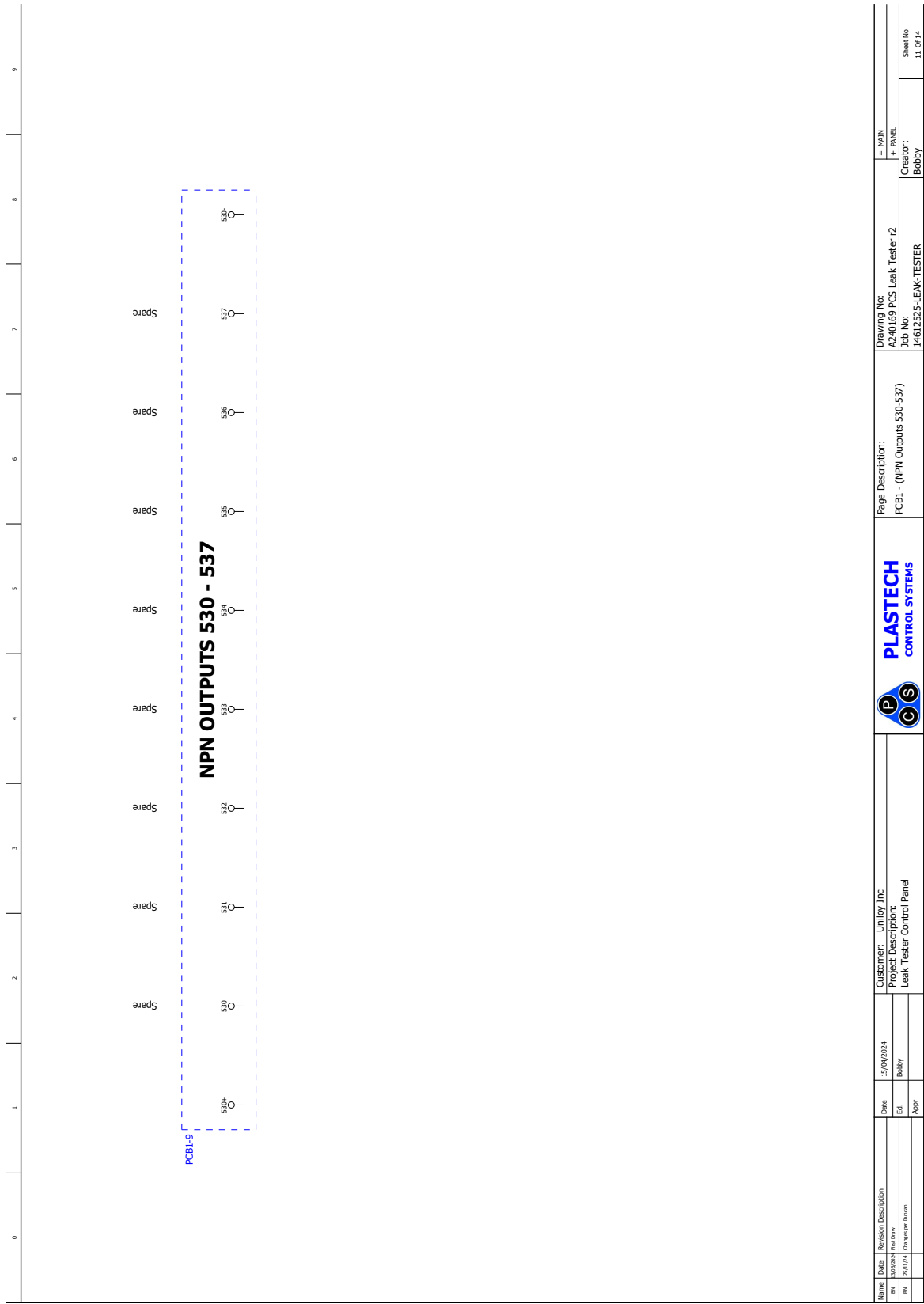

Name	Revision Description	Date	15/09/2024	Customer:	Umiloy Jinc	Drawing No:	= MAIN
BN	14/09/24 Final Draw	Ed:	Bobby	Project Description:	Leak Tester Control Panel	AZ40169 PCS Leak Tester r2	# PANEL
BN	25/11/24 Change per drawing	Appr:		Page Description:	PCB1 - (NPN Outputs 530-537)	Job No:	14612525-LEAK-TESTER
				Creator:	Bobby	Sheet No	11 OF 14



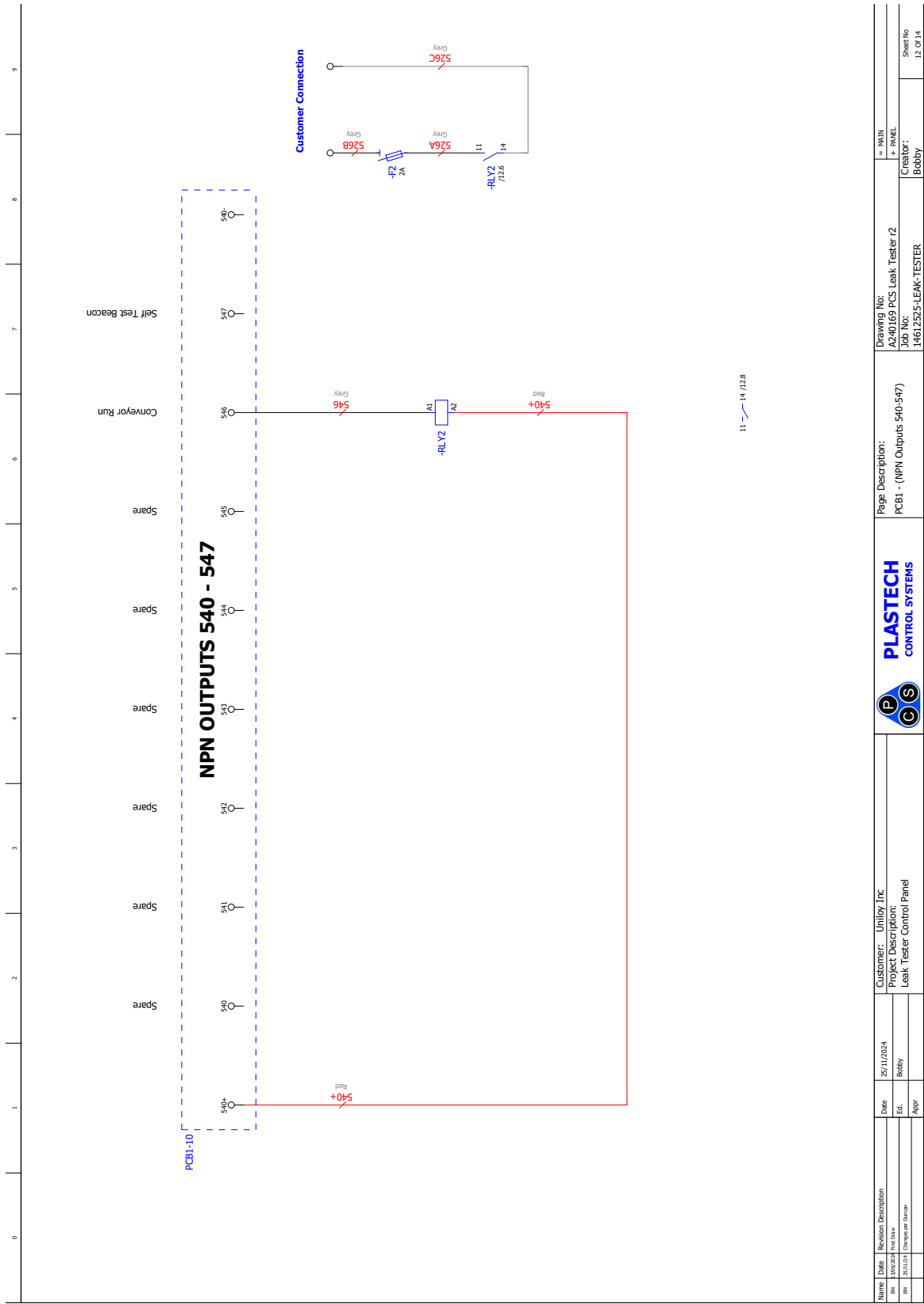

11 - 14 / 12,8

Name	Revision Description	Date	26/11/2024	Customer: Umiloy, Inc.	Page Description:	Drawing No:	# MAIN
BN	Initial Function	Edt	Bobby	Project Description:	PCB1 - (NPN Outputs 540-547)	AZ40169 PCS Leak Tester r2	# PANEL
BN	25/11/24 Complete Drawn	Appr		Leak Tester Control Panel	PCB1 - (NPN Outputs 540-547)	Job No:	14612525-LEAK-TESTER
						Creator:	Bobby
						Sheet No	12 OF 14



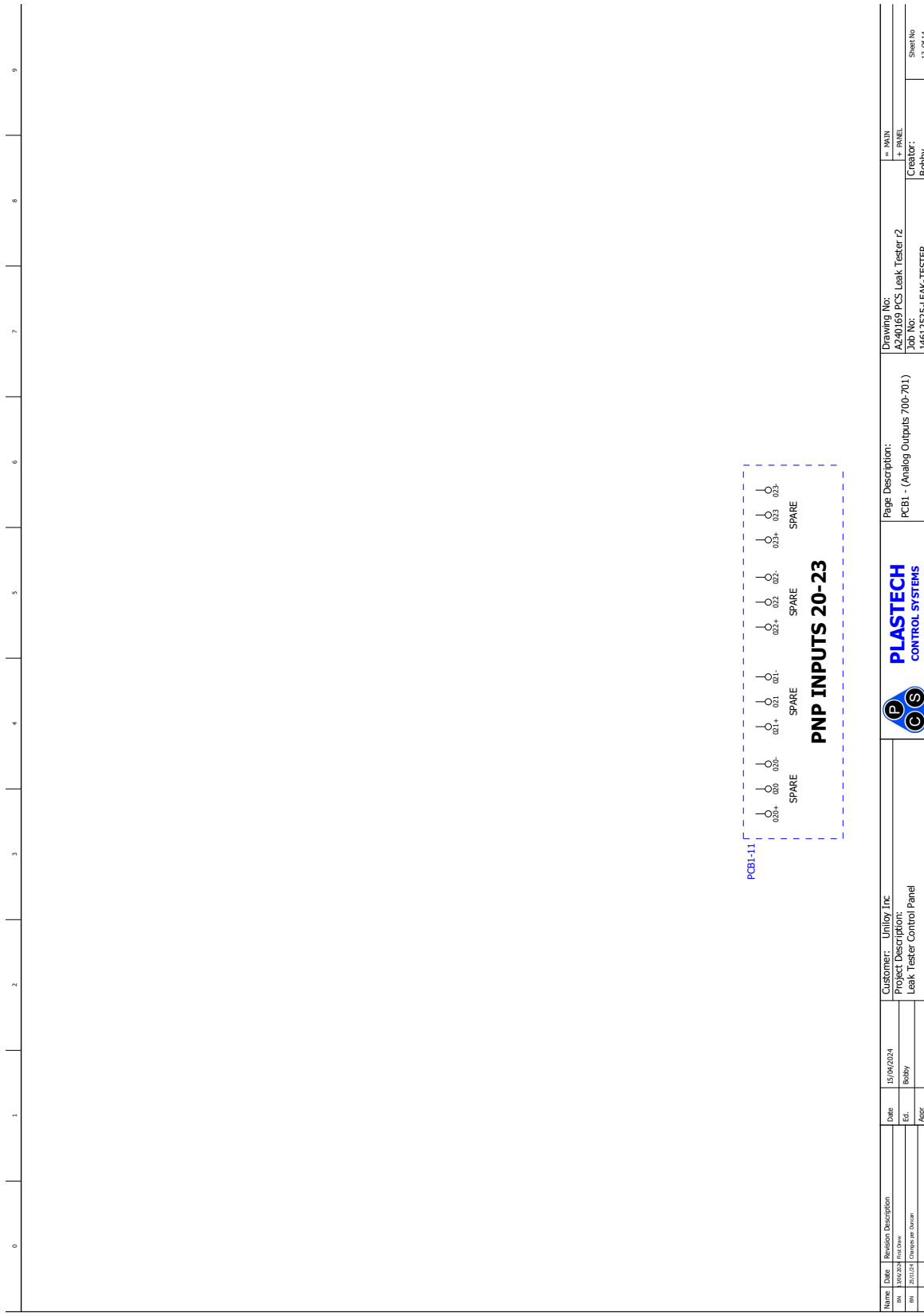

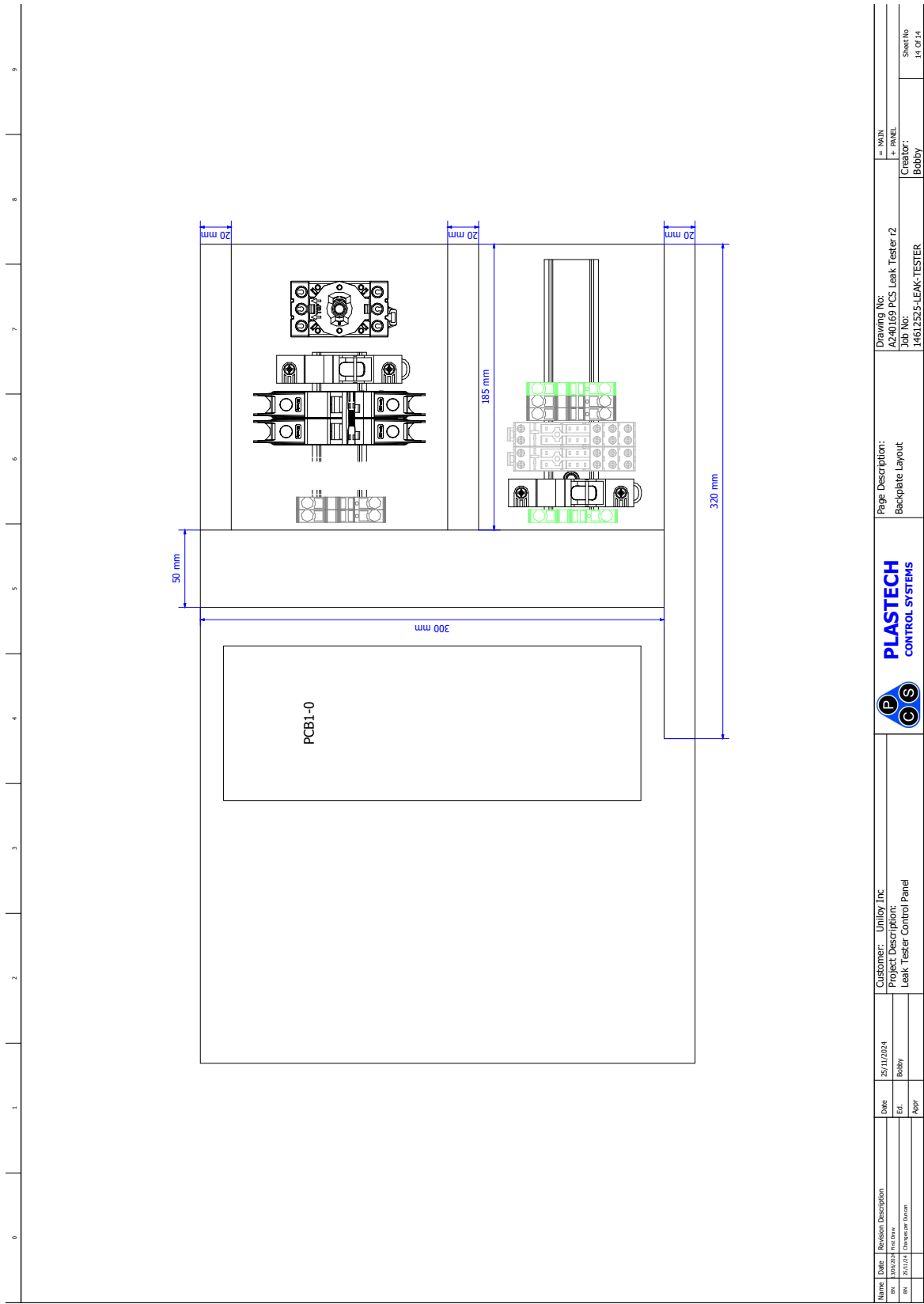

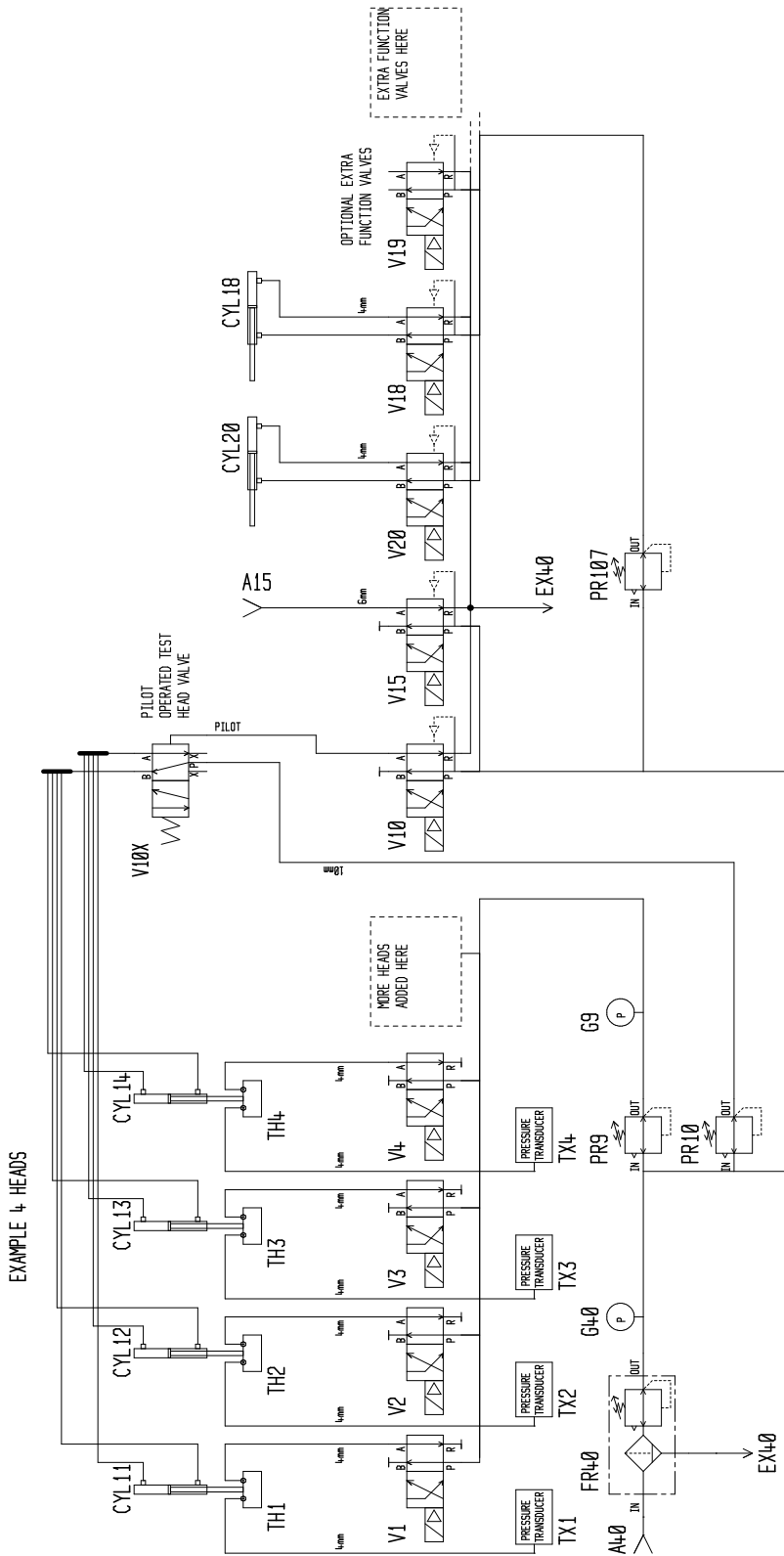

Figure 10.1 Pneumatics Diagram

11 Maintenance

11.1 Periodic Maintenance

Every week, check the condition of the test head seals. Replace any that are worn. The system will start to fail bottles if the sealing surface becomes too irregular.



Every year, or when discolored, replace the air filter in the filter-regulator assembly.

Figure 11.1

Every month, observe the operation of the machine. Note any air cylinders that are showing signs of wear, air leaks or excess "sticktion". Removing the air supply to the machine and moving by hand can check the action of the cylinders. The cylinder pistons should move easily. Replace any that are faulty.

12 Leak Detector Parts List

The following tables comprise a parts list for the machine. Spare parts can be ordered from Plastech Control Systems using the part number listed under "Part ID".

The numbers under "Ref" are the references as they appear on drawings; the numeric part identifies the function as explained earlier.

Ref	Part ID	Description	Function
SW40	76	Isolator, Mains, Interlocked	Mains Isolator
PB41	1332	LTU9000-DC-C Internal Cabinet Stop Switch Assy	
PB44	1334	LTU9000-DC-C Internal Cabinet Start Switch Assy	
PB41	1335	LTU9000-DC-C External Cabinet Stop Actuator	
PB44	1336	LTU9000-DC-C External Cabinet Start Actuator	
L43	1337	LTU9000-DC-C Power Indicator Assembly	
L44	1338	LTU9000-DC-C Run Indicator Assembly	
PR9,10	748	Pressure regulator, 1/4 ported, low pressure	Pressurization
9	344	Tubing, Silicone Rubber, 1.6mm wall thickness, ID 3.2	Transducer Piping
	120	Tubing, Blue, 4mm O/D, 10m	
	122	Tubing, Blue, 8mm O/D	
	121	Tubing, Blue, 6mm O/D,10m	
EX40	968	Muffler, 3/8 ported 3.3 CV	System exhaust
G1,2,10	282	Pressure Gauge, panel mount, 40mm dial, 4 bar	Front Panel gauges
G40	62	Pressure Gauge, screw in, 1/8 ported, 0-10 Bar	Mains Air In
PR10	748	Pressure regulator, 1/4 ported, low pressure	Test head force
PR40	281	Filter Regulator, auto drain, 1/4 ported	NR1 Main air in

Table 12.1 Control Cabinet Parts List

Ref	Part ID	Description	Function
10	833	Manifold block assy 6mm	Test Head Down
40	839	Manifold supply/exhaust assy (for R)	System Supply
10,9	810	Manifold block disc	Test Head, Pressurization
10,9	831	Supply / Exhaust Block Assy (std)	Test Head, Pressurization
15,17,20	834	Valve, common pilot	Reject, Stop, Separate
15,17,20	832	Manifold block assy 4mm	Reject, Stop, Separate
10	835	Valve, external pilot supply	Test Head Down
9	835	Valve, external pilot supply	Pressurization
40	830	Manifold DIN rail size 18 (323mm)	
40	828	Manifold End Piece U side	
40	829	Manifold End Piece D side	

Table 12.2 Valve Manifold Parts List

Ref	Part ID	Description	Function
17	AFMA20X 80	Cylinder, 20mm bore, stroke 80mm	for 80mm Stop Cylinder
17	AFMA20X 100	Cylinder, 20mm bore, stroke 100mm	for 100mm Stop Cylinder
17	AFMA20X 120	Cylinder, 20mm bore, stroke 120	for 120mm Stop Cylinder
20	AFMA20X 80	Cylinder, 20mm bore, stroke 80mm	for 80mm Separator Cylinder
20	AFMA20X 100	Cylinder, 20mm bore, stroke 100mm	for 100mm Separator Cylinder
20	AFMA20X 120	Cylinder, 20mm bore, stroke 120	for 120mm Separator Cylinder
10	AFMA25X25	Cylinder, 25mm bore, stroke 25mm	Test Head Cylinders
15	342	Fitting, Bulkhead, Chromed, push-over, 6mm	Reject Blower
10	341	Fitting, Elbow, 1/8 : 4mm	Test Head Cylinders
9	752	Fitting, Elbow, Push Over, 1/8 : 4mm	Test Head Fitting (fill)
9	753	Fitting, Elbow, Push Over, 1/8 : 6mm	Test Head Fitting (sense)
10	751	Fitting, Manifold, 8mm : 10 x 4mm	Test Head Cylinders
40	120	Tubing, Blue, 4mm O/D	
40	121	Tubing, Blue, 6mm O/D	
40	122	Tubing, Blue, 8mm O/D	

Table 12.3 Test Fixture Parts List

Ref	Part ID	Description
40		LTU9000 Controller Panel (inc. screen+panel)
40	146101	PCB-1260-01 1 Head I/O Board
40	146102	PCB-1260-02 2 Head I/O Board
40	146103	PCB-1260-03 3 Head I/O Board
40	146104	PCB-1260-04 4 Head I/O Board
40	146106	PCB-1260-06 6 Head I/O Board
40	146108	PCB-1260-08 8 Head I/O Board
40	146112	PCB-1260-12 12 Head I/O Board

Table 12.4 Circuit Boards

13 Fallen Bottle Ejection

This is very useful on lines where it is possible for a bottle to fall over. When this option is fitted, bottles are ejected off of the conveyor before they get into the leak tester, preventing a bottle jam.

The system works as follows:

The Fallen Sense Top photoswitch monitors the bottles passing by. Whenever the signal disappears, after a short set ``Fallen Sense Delay`` the Fallen Sense Bottom photoswitch signal is checked. If this signal is present, and the Top photoswitch signal is still not present, then a fallen bottle is detected and the Fallen Sense Eject Blower is turned on for the set Fallen Sense Eject Time. This ejects the bottle from the conveyor.

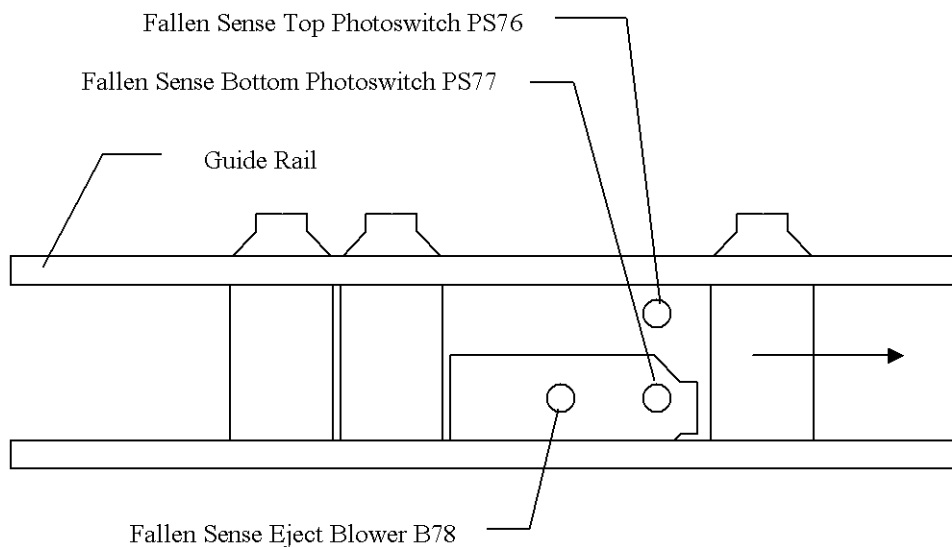

Figure 13.1 Fallen Bottle Sensing System Layout

13.1 Fallen Bottle Sensing Installation and Setting Up

The fallen bottle sensing can be anywhere, but is ideally best located immediately before the leak test area. The guide rails should be prepared so that a fallen bottle

can be ejected, while still allowing bottles to queue in a stable manner. It should normally be possible to provide a continuous lower guide rail, with the fallen bottle being blown over the top.

There are two settings involved, these are located by pressing the PAGE button on the touchscreen controller until they appear on their own page ``OTHER SETTINGS''. Adjust the horizontal position of the two photoswitches shown above so that when a single upright bottle passes, the signals go off at the same time. Adjust the vertical position so that the lower photoswitch sees a bottle in both positions (upright and fallen) while the upper photoswitch can only see upright bottles.

Set ``Fallen Sense Detect Delay'' to 0.1 seconds.

Set ``Fallen Sense Eject Time'' to 1.0 second.

At this point, fallen bottles should be detected and blown off of the conveyor. Adjust the blower as required to efficiently eject the bottle. Adjust the eject time as required to blow the bottle cleanly away without disturbing following containers.

13.2 Handle Flash Detection

This is an extra facility, which can be used in conjunction with the infrared wall thickness measurement option above. At the point where the wall thickness measurement is triggered, the output from a handle flash sensor is sampled. If the sensor is active, the bottle is rejected due to handle flash. The alignment along the conveyor is critical.

The handle sensor should be positioned so that it is looking at the handle area as the bottle fully interrupts the thickness measurement beam. This position is best found by experiment.

Produced by Plastech Control Systems Ltd

Revision 4.1

As a policy of continual improvement, Plastech Control Systems Ltd reserve the right to alter specifications without prior notice.

Except as permitted by such licence, no part of this publication may be reproduced, stored in retrieval system or transmitted, in any form or any means, electronic, mechanical, recording, or otherwise, without prior written permission of Plastech Control Systems Ltd.

Plastech Control Systems Ltd
Unit 10 Ketterer Court
Jackson Street
St Helens
Merseyside UK
WA9 3AH

Tel: +44 (0)1744 734 123
Fax: +44 (0)1744 734 340
USA Number 414 426 8843
Email: sales@plastech-controls.com
Website: www.plastech-controls.com

www.plastech-controls.com